

DICKINSON COUNTY Bridge New - CCS PROJECT NO. L-669--73-30

Letting Date August 12, 2025

UTILITIES

Alliant Energy
 Eric Munson
 1301 20th/ St.
 Spirit Lake, Iowa 51360
 712-336-6006
 ericmunson@alliantenergy.com

Iowa Lakes Electric Coop
 702 South 1st Street
 Estherville, Iowa 51334
 800-225-4532



Iowa Great Lakes Sanitary District
 303-28th Street
 Milford, Iowa 51351
 712-338-2626
 iglsd@iglsd.com

Black Hills Energy
 Ashley Johnson
 801 14th Ave. E
 Spencer, Iowa 51301
 712-580-6033
 ashley.johnson@blackhillscorp.com

Mediacom
 Jeff Anfinson
 1721 N Hwy Blvd.
 Spencer, Iowa 51301
 712-330-5198
 janfinson@mediacomcc.com

Century Link
 Christopher Lovelace
 702-544-8783
 christopher.g.lovelace@centurylink.com

Milford Communications
 Josh Sandbulte
 806 Okoboji Avenue
 Milford, IA 51351
 712-338-4967
 josh@sandbulte.com

City of Milford
 806 N Avenue
 Milford, Iowa 51351
 712-338-2741
 publicworks@milford.ia.us

Milford Municipal Utilities
 806 N Avenue
 Milford, Iowa 51351
 712-338-2401

ITC Midwest
 kwhisner@itctransco.com



Highway Division

PLANS OF PROPOSED IMPROVEMENT ON THE

**SECONDARY ROAD SYSTEM
 DICKINSON COUNTY
 Bridge New - CCS**

Lower Gar Outlet on 230th Ave., Between Sections 5 & 6, T98N, R36W

Refer to the Proposal Form for a list of applicable specifications.

Scales: As Noted

PROJECT NO.: L-669--73-30

PROJECT TRAFFIC CONTROL PLAN:

THIS ROAD WILL BE CLOSED TO THROUGH TRAFFIC DURING CONSTRUCTION. LOCAL TRAFFIC TO ADJACENT PROPERTIES WILL BE MAINTAINED AS PROVIDED FOR IN ARTICLE 1107.08 OF THE CURRENT STANDARD SPECIFICATIONS. TRAFFIC CONTROL DEVICES, PROCEDURES, LAYOUTS, SIGNING, AND PAVEMENT MARKINGS INSTALLED WITHIN THE LIMITS OF THIS PROJECT SHALL CONFORM TO THE "MANUAL ON UNIFORM TRAFFIC CONTROL DEVICES FOR STREET AND HIGHWAYS" AS ADOPTED BY THE DEPARTMENT PER 761 OF THE IOWA ADMINISTRATIVE CODE (IAC) CHAPTER 130.

Project Number: L-669-73-30

INDEX OF SHEETS

TOTAL SHEETS = 23

No.	Description
A.01	TITLE SHEET, UTILITIES
B.01-B.02	TYPICAL SECTIONS
C.01	ESTIMATE OF QUANTITIES
C.02-C.03	REFERENCE NOTES, GENERAL NOTES
C.04	ROAD & BRIDGE STANDARDS
C.05	TABS FOR EXCAVATION, PCC
C.06	TABS FOR CONCRETE, STOCKPILES, REVETMENT, SEEDING
D.01-D.02	PLAN AND PROFILE SHEETS
Q.01-Q.03	SOIL BORINGS, PILING NOTES
U.01	BR-205 DETAILS
V.01	SITUATION PLAN, LONGITUDINAL CROSS-SECTION
V.02	PILE ENCASEMENT DETAILS
V.03	TOP OF SLAB ELEVATIONS
W.01-W.05	MAINLINE CROSS-SECTIONS

MILEAGE SUMMARY

Div.	Location	Lin. Ft.	Miles
	Sta. 44+45 to Sta. 49+50	505.000	0.100

STANDARD ROAD & BRIDGE PLANS

See Sheet C.04 for a tabulation of applicable Standard Road Plans and Bridge Standard Plans.

DRAWING APPROVAL

ALL SHOP DRAWINGS AND FALSEWORK DRAWINGS THAT REQUIRE APPROVAL SHALL BE SUBMITTED TO AND APPROVED BY THE CONTRACTOR, WHO SHALL THEN SUBMIT THEM TO THE DICKINSON COUNTY ENGINEER, FOR REVIEW AND APPROVAL.

ADDRESS: 1802 HILL AVENUE
 SUITE 2101
 SPIRIT LAKE, IOWA 51360
 TELEPHONE : (712) 336-2944, FAX (712) 336-1601

THESE SHOP DRAWINGS SHALL NOT BE SENT TO IOWA D.O.T. OFFICE OF BRIDGES AND STRUCTURES.
 A MINIMUM 5 FT. WIDE "CATWALK" WILL BE REQUIRED ON MINIMUM OF ONE SIDE OF BRIDGE FALSEWORK.

281-1
10-18-16

SECTION 404 PERMIT AND CONDITIONS

Construct this project according to the requirements of U.S. Army Corps of Engineers Nationwide Permit 14, Permit No. CEMVR-RD-2023-1589. A copy of this permit is available from the Iowa DOT website (<http://www.envpermits.iowadot.gov>). The U.S. Army Corps of Engineers reserves the right to visit the site without prior notice.

This project is covered by Iowa DNR Floodplain Development Permit No. FP2023-2098FP-01 and Sovereign Lands Construction Permit No. 2023-2098SL-01.

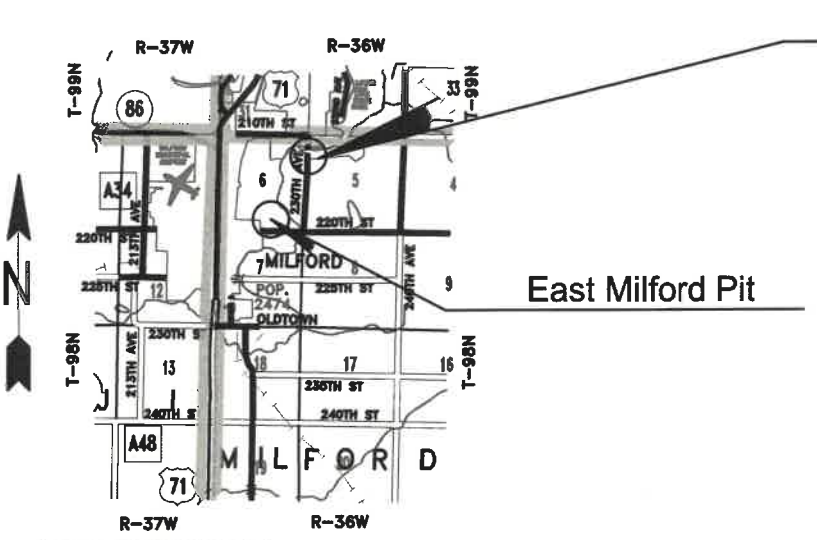

STA. 47+00.00
 PROPOSED 140'-0 x 44'-6
 CONTINUOUS CONCRETE
 SLAB BRIDGE, 0° SKEW
 FHWA # (None)

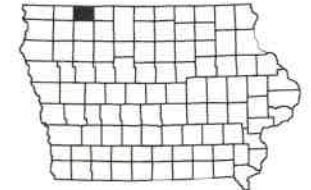

2023 AADT 760 V.P.D.

William C. Leopold

Ging Jones

Stephen C. Dullborg

Steve B. Clark

Jeri Markwardt

Approved: July 8, 2025
 Board of Supervisors

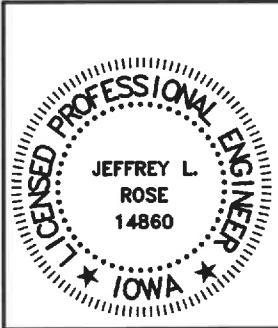

I hereby certify that this engineering document was prepared by me or under my direct personal supervision and that I am a duly Licensed Professional Engineer under the laws of the State of Iowa.

Jeffrey L. Rose 7/8/25
 Jeffrey L. Rose (Date)
 My license renewal date is December 31, 2026
 Pages or Sheets covered by this seal:
 A.01 THROUGH W.05

Normal section shown may be modified appropriately in areas of superelevated curves or other locations specifically designated by the Engineer.

See plan & profile sheets and cross sections for additional details of ditches and backslopes.

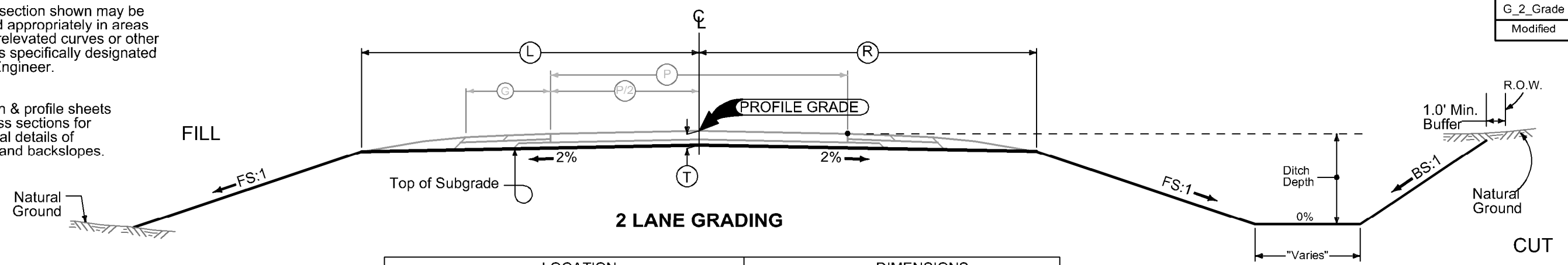

LOCATION		DIMENSIONS						
ROAD IDENTIFICATION	STATION TO STATION	L Feet	R Feet	P Feet	T Inch	FS	BS	
230th Ave.	44+45 45+58	Varies	Varies	22.0	14.0	4:1	4:1	
230th Ave.	45+58 46+28.5	Varies	Varies	47.17	36.0-48.0	4:1	4:1	
230th Ave.	47+71.5 48+42	Varies	Varies	47.17	36.0-48.0	4:1	4:1	
230th Ave.	48+42 49+50	Varies	Varies	22.0	14.0	4:1	4:1	

See Cross-Sections for Subgrade widths and Subbase Depths.

DESIGN FOR
 140' x 44' CONTINUOUS CONCRETE SLAB BRIDGE
 STA. 47+00 0° SKEW
 INTEGRAL ABUTMENTS 42'-6" END SPANS 55'-0" CENTER SPAN
 P10L TYPE 3 PILING-FULL ENCASED MONOLITHIC PIER CAPS
 J44-14 DICKINSON COUNTY

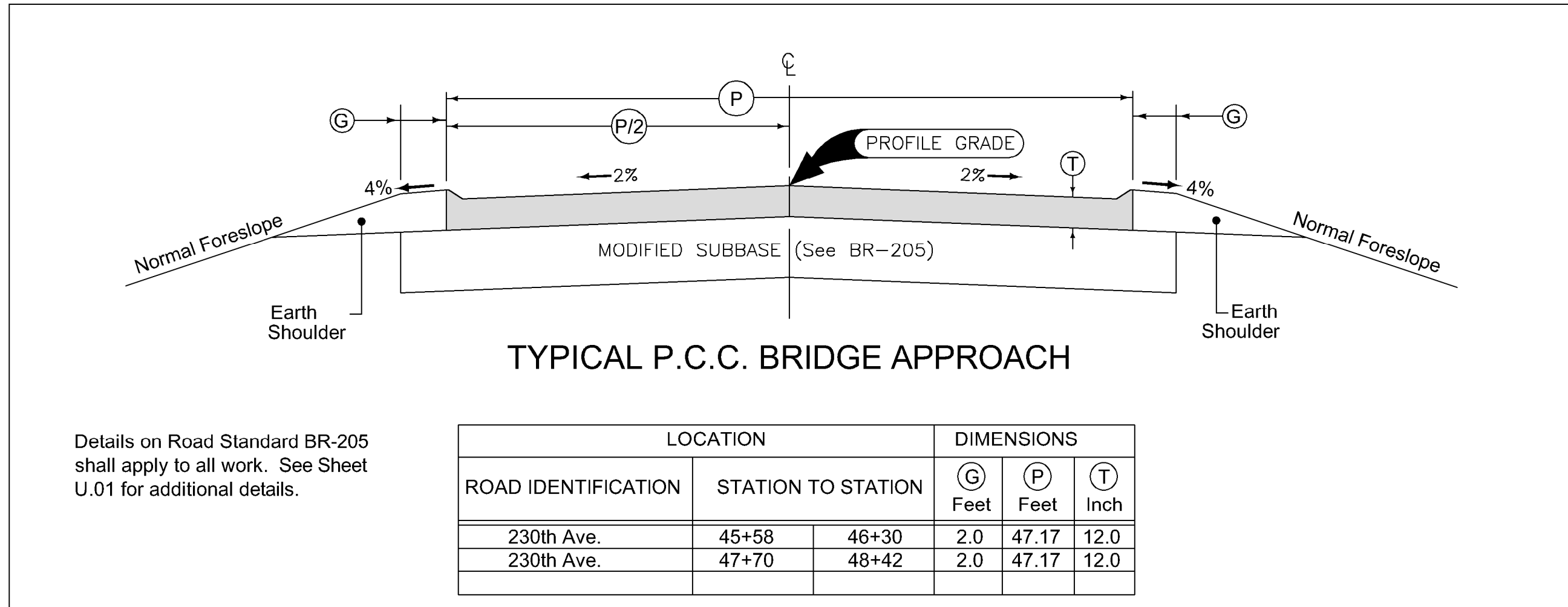
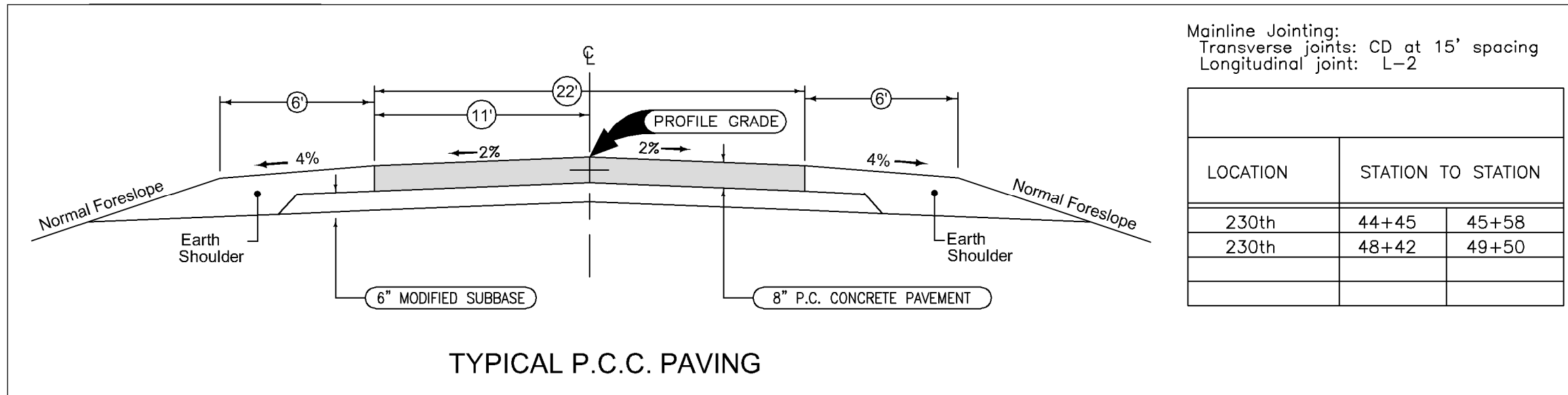

DESIGN FOR
 140' x 44' CONTINUOUS CONCRETE SLAB BRIDGE
 STA. 47+00 0° SKEW
 INTEGRAL ABUTMENTS 42'-6" END SPANS 55'-0" CENTER SPAN
 P10L TYPE 3 PILING-FULL ENCASED MONOLITHIC PIER CAPS
 J44-14 DICKINSON COUNTY

ESTIMATE OF QUANTITIES
PROJECT NO. L-669--73-30 LOWER GAR OUTLET

REF. NO.	ITEM NO.	ITEM DESCRIPTION	UNIT	ABUTMENTS (2)	PIERS (2)	SUPERSTRUCTURE	TOTAL
1	2102-2710070	EXCAVATION, CLASS 10, ROADWAY AND BORROW	CY				1,036.000
2	2102-2712015	EXCAVATION, CLASS 12, BOULDERS OR ROCK FRAGMENTS	CY				10.000
3	2104-2710020	EXCAVATION, CLASS 10, CHANNEL	CY				1,619.000
4	2105-8425015	TOPSOIL, STRIP, SALVAGE AND SPREAD	CY				227.000
5	2115-0100200	MODIFIED SUBBASE, PLACE ONLY	CY				128.500
6	2123-7450020	SHOULDER FINISHING, EARTH	STA				5.710
7	2301-0690205	BRIDGE APPROACH, BR-205	SY				812.400
8	2301-1032080	STANDARD OR SLIP FORM PORTLAND CEMENT CONCRETE PAVEMENT, CLASS C, CLASS 2 DURABILITY, 8 IN.	SY				650.150
9	2315-8275030	SURFACING, DRIVEWAY, CLASS C GRAVEL	TON				75.000
10	2401-6745650	REMOVAL OF EXISTING STRUCTURES	LS				1.000
11	2402-2720000	EXCAVATION, CLASS 20	CY				126.000
12	2402-2721000	EXCAVATION, CLASS 21	CY		281.000		281.000
13	2402-2722000	EXCAVATION, CLASS 22	CY				310.000
14	2403-0100010	STRUCTURAL CONCRETE (BRIDGE)	CY	31.400	60.600	490.600	582.600
15	2404-7775000	REINFORCING STEEL	LB	-	4,412.000	-	4,412.000
16	2404-7775005	REINFORCING STEEL, EPOXY COATED	LB	4,718.000		111,411.000	116,129.000
17	2404-7775009	REINFORCING STEEL, STAINLESS STEEL	LB			3,104.000	3,104.000
18	2414-6424124	CONCRETE OPEN RAILING, TL-4	LF				302.000
19	2435-0250110	INTAKE, SW-501 MODIFIED, ADJUST ONLY	EACH				1.000
20	2501-0201042	PILES, STEEL, HP 10 X 42 (18 @ 60')	LF	1,080.000			1,080.000
21	2501-0201253	PILES, STEEL, HP 12 X 53 (34 @ 60')	LF		2,040.000		2,040.000
22	2501-6335010	PREBORED HOLES	LF	180.000			180.000
23	2507-3250005	ENGINEERING FABRIC	SY				277.000
24	2507-6800061	REVTMENT, CLASS E	TON				164.000
25	2507-8029000	EROSION STONE	TON				25.000
26	2510-6745850	REMOVAL OF PAVEMENT	SY				1,410.090
27	2527-9263109	PAINTED PAVEMENT MARKING, WATERBORNE OR SOLVENT-BASED	STA				13.470
28	2528-2518000	SAFETY CLOSURE	EACH				2.000
29	2528-8445110	TRAFFIC CONTROL	LS				1.000
30	2533-4980005	MOBILIZATION	LS				1.000
31	2555-0000010	DELIVER AND STOCKPILE SALVAGED MATERIALS	LS				1.000
32	2601-2634100	MULCHING	ACRE				0.450
33	2601-2636015	NATIVE GRASS SEEDING	ACRE				0.450
34	2601-2642100	STABILIZING CROP - SEEDING AND FERTILIZING	ACRE				0.450
35	2602-0000020	SILT FENCE	LF				390.000
36	2602-0000212	FLOATING SILT CURTAIN (HANGING)	LF				400.000
37	2602-0000312	PERIMETER AND SLOPE SEDIMENT CONTROL DEVICE, 12 IN. DIA.	LF				200.000
38	2602-0010010	MOBILIZATIONS, EROSION CONTROL	EACH				3.000
39	2602-0010020	MOBILIZATIONS, EMERGENCY EROSION CONTROL	EACH				1.000

DESIGN FOR
140' x 44' CONTINUOUS CONCRETE SLAB BRIDGE
STA. 47+00 0' SKEW
INTEGRAL ABUTMENTS 42'-6 END SPANS 55'-0 CENTER SPAN
J44-14 BRIDGE STANDARDS
DICKINSON COUNTY

REFERENCE NOTES

1. Exc., Class 10, Roadway & Borrow:
Quantities shown are for construction of the roadway, and entrances; see typical sections, plan and profile sheets, cross-sections, and applicable Road Standards for details. See Sheet C.05 for Earthwork Tabulation of quantities. Excess material shall be removed from the Project, see Item No. 31. Type B Compaction is required.
2. Exc., Class 12, Boulders:
Estimated quantity, payment to be based on field measurement. Clean boulders may be used in the lower lift of the revetment or be removed from the Project, see Item No. 31.
3. Class 10 Channel:
The Contractor is to clear and shape the channel between the Class 20 limits at the abutments, and below the existing culverts. See Sheet V.01 for details. The areas of the existing box culverts have been deducted from the area of Class 10 Channel.
The berms shall be constructed prior to driving the abutment piling.
Excess material not used shall be removed from the Project site, see Item No. 31.
4. Topsoil, Strip, Salvage & Spread:
This item is for Topsoil along the finished shoulders, slopes and ditches. A Minimum of 4" of Topsoil shall be spread over all shoulders, slopes, and ditches. See Sheet C.05 for Tabulation of Topsoil for locations and quantities.
5. Modified Subbase:
See Tabulation on Sheet C.05 for quantity estimates. Item is for the 28'x 6" Modified Subbase under the PCC Pavement outside of the bridge approaches.
The Contractor may use crushed P.C.C. material with a nominal minus 2 inch size, free of cost, from a stockpile in a County owned pit, located at East Milford Pit, 2246 220th Street, Milford, Iowa. The Contractor shall load, haul, place, and compact. Material for use on the Project only.
6. Shoulder Finishing:
See Typical Sections on Sheet B.02 for construction details.
Item is for shaping, compacting and finishing the Class 10 and Topsoil material after the PCC work has been completed. The top 4" of material shall be Topsoil.
Specification 2123.03 B 2 regarding the final layer shall not apply to the Earth Shoulder work. The entire final layer of the shoulder shall be rolled at least 3 times.
7. Bridge Approach Section:
See Tabulation of Bridge Approach Section on Sheet C.05. Certified Plant Inspection is required for all concrete incorporated into the Project.
Price bid shall include all materials and details shown on Road Standard BR-205, except the Contractor may use crushed P.C.C. material with a nominal minus 2 inch size, free of cost, from a stockpile in a County owned pit, located at East Milford Pit, 2246 220th Street, Milford, Iowa for the Modified Subbase. The Contractor shall load, haul, place, and compact. Material for use on the Project only.
8. P.C.C. Pavement:
The pavement shall be Class C Portland Cement Concrete. The coarse aggregate for the P.C. Concrete shall be of a minimum of Class 2 Durability. Transverse CD joints shall be at 15 foot intervals, with a L-2 longitudinal joint and #5 bars at 30" centers. Epoxy coated steel will be required. All joints shall be filled with sealant. See Typical Sections for additional details.
Grooving shall conform to Specification 2301.03 H 3 Macrotecture.
The Contractor shall provide the Certified Plant Inspection.
Dickinson County will establish the proposed grade line and the necessary stakes to complete this work.
9. Driveway Surfacing:
Estimated Quantity, Payment to be based on field measurement. Locations include entrances on North side of bridge.
Contractor shall furnish, deliver, spread and finish blade the granular material. Price bid shall include replacing, blading, and consolidating, any removed granular material as a base layer, with a nominal 6" Surface Course.

10. Removal of Existing Structures:
See Tabulation of Deliver & Stockpiling on Sheet C.06 for pipe sizes and details. The areas of the existing box culverts have been deducted from the area of Class 10 Channel and this excavation shall be included in the Removal bid item.
Culverts shall remain the property of the County and shall be carefully removed and salvaged without damaging the existing culverts. Culverts shall be hauled and stockpiled as per Item No. 31.
11. Excavation, Class 20:
This item consists of excavation for the abutment work. See Earthwork Tabulations on Sheet C.05. Class 20 Excavation for the Abutments is based on the assumption that the channel excavation and the necessary berm construction have been completed. Unsuitable material shall be removed from the Project site under Item No. 31.
12. Excavation, Class 21:
Item is for the area of encasement of the piers and the area of streambed below the Excavation Classification Line. Unsuitable material shall be removed from the Project site under Item No. 31. Costs for placing, pumping and removal of any possible cofferdams shall be considered included in the price bid for Excavation, Class 21. Section 2402 and Section 2405 shall apply to this work.
13. Excavation, Class 22:
Item is for the existing boulders along the embankment and culverts. Estimated quantity, payment to be made on Field Measurements. Clean boulders may be used in the lower lift of the revetment or be removed from the Project, see Item No. 31.
14. Structural Concrete:
All Structural Concrete is to be Class "C". See Sheet C.06 for tabulation of placement quantities.
Quantities are based on: monolithic pier caps with seventeen (17) HP 12x53 Steel Bearing Pile bents (See J44-25-14 & J44-26-14); integral abutments with nine (9) – HP 10x42 Steel Bearing Pile per footing (See J44-39-14, & J44-44-14); and a 140' Superstructure @ a 0° Skew, with monolithic pier caps, TL-4 open rail (See J44-48-14 & J44-49-14), and wings. Full encasement of the pier piles is also included. See Sheet V.02 for encasement details. Price bid shall include cost for furnishing and placing subdrains, concrete sealer, tar paper and preformed joint material are also included.
All backfill behind the abutments, between the wing-walls shall be porous and granular backfill as detailed within. The remainder of the abutment excavation shall be backfilled with soil. Cost of porous and granular backfill shall be included in the price bid for "Structural Concrete".
No additional payment will be allowed for heating and protection of concrete, if necessary.
The Contractor shall perform all necessary Certified Plant Inspection as part of this item.
Article 2428 Bridge Deck Smoothness, does not apply to this Project.
Falsework Note: A minimum 5 ft wide "catwalk" will be required on minimum of one side of the bridge falsework.
- 15.-17. Reinforcing Steel, Epoxy, Regular & Stainless:
Quantities are based on: monolithic pier caps with seventeen (17) HP 12x53 Steel Bearing Pile bents (See J44-25-14 & J44-26-14 & P-10L); integral abutments with nine (9) – HP 10x42 Steel Bearing Pile per footing (See J44-39-14, & J44-44-14); and a 140' Superstructure @ a 0° Skew, with monolithic pier caps, TL-4 open rail (See J44-48-14 & J44-49-14), and wings. Also see BR-205 for reinforcement required and details. Full encasement of the pier piles is also included. See Sheet V.02 for encasement details.
The pile spirals and spacers in the abutment footings may be normal or epoxy coated at the contractors option.
18. Open Rail:
Quantities based on: a 140' Superstructure @ a 0° Skew, TL-4 open rail (See J44-48-14 & J44-49-14).
Concrete shall be Class "C".
Price bid for Concrete Open Railing shall include Concrete Sealer applied to the open rail as shown on J44-16-14.
The Contractor shall perform all necessary Certified Plant Inspection as part of this item.
No additional payment will be allowed for heating and protection of concrete, if necessary.
19. Intake, Modify:
Item is for any adjustment required at Sta. 46+00 Rt. to tie the bridge approach into the existing curb & gutter section or removal of curb & gutter North of the intake.

DESIGN FOR
140' x 44' CONTINUOUS CONCRETE SLAB BRIDGE
STA. 47+00 0° SKEW
INTEGRAL ABUTMENTS 42'-6" END SPANS 55'-0" CENTER SPAN
J44-14 BRIDGE STANDARDS
DICKINSON COUNTY

REFERENCE NOTES - Continued

20.-21. Steel Piles:

Piles are required as follows:

South Abutment	HP10 x 42 Steel H Pile	9 pile @ 60 L.F. Each	88 Ton Minimum Bearing
South Pier	HP12 x 53 Steel H Pile	17 pile @ 60 L.F. Each	90 Ton Minimum Bearing
North Pier	HP12 x 53 Steel H Pile	17 pile @ 60 L.F. Each	90 Ton Minimum Bearing
North Abutment	HP10 x 42 Steel H Pile	9 pile @ 60 L.F. Each	88 Ton Minimum Bearing

See Pile notes on Sheet Q.03.

The piling shall be driven to full penetration if practical, but in no case less than the pile bearing required. If re-taps are required, they shall be performed by the Contractor at No Additional Cost. The abutment berms shall be constructed as per plan prior to driving the pile.

Sounding data shown on plans is shown for design and estimating purposes only and no guarantee is given that conditions other than those indicated will not be encountered.

Due to the presence of possible boulders and cobbles in the sounding data, Cast in one piece steel pile points are required for all piling on the abutments and piers, in accordance with Article 4167.02 of the current Standard Specifications and Materials I.M. 468.

Epoxy coated cap steel shown on P10-L shall be required and included in the price bid for Piles, Steel, HP12 x 53.

22. Prebored Holes:

The bridge contractor shall prebore holes for abutment piles. Holes shall be bored to the elevations shown on the "Longitudinal Section Along Centerline of Roadway" on Sheet V.01. Piles shall be driven through the holes to at least the specified design bearing. Temporary casings and/or bentonite slurry may be required as part of this item.

23. Engineering Fabric:

Estimated quantity, payment on field measurement. This item is for placing engineering fabric on the bridge slopes, and abutment wing armoring. See Sheet V.01 for details and placement limits and Sheet C.06 for location tabulation.

24. Revetment:

Estimated quantity, payment on field measurement. This item is for placing revetment on the bridge slopes. Quantity is based on nominal 18" thick revetment. See Sheet V.01 for details and placement limits and Sheet C.06 for location tabulation.

25. Erosion Stone:

Estimated quantity, payment on field measurement. This item is for placing erosion stone on the top of the bridge berms along the abutments and for abutment wing armoring. Quantity is based on a nominal 9" placement depth. See tabulation on Sheet C.06 and detail on Sheet V.01.

26. Pavement Removal:

Existing pavement consists of a nominal 7"x 22' 1988 P.C.C. Pavement. Saw cuts will be required at the abutting pavement prior to placement of the new P.C.C. These will not be paid for separately, but included in the price bid for Removal of Pavement. Remove pavement from Project site per Item No. 31.

27. Painted Pav't. Markings:

Estimated quantity, payment to be made on field measurements. Paint quantity based on 4" wide paint for Double Yellow (DCY4 factor 1.34) and White Edge line (ELW4 factor 0.67) for the Project length.

28. Safety Closure:

29. Traffic Control:

Traffic Control for the Project will be provided by the Contractor. Included in this bid item are all Project Construction Signs necessary for the type of work being constructed. A detour route is not required for this Project. Dickinson County will place permanent signing at the completion of the Project.

30. Mobilization:

Staging and storage area is available at the County Maintenance Shed at 2246 220th Street, Milford, Iowa.

31. Deliver and Stockpile:

See Tabulation on Sheet C.06 for details. Culverts shall be salvaged without damaging, hauled to address noted, and neatly stockpiled in designated areas. The Contractor shall furnish the necessary equipment to unload and stack and/or stockpile. Removed pavement and unsuitable excavation shall be hauled to address noted and neatly stockpiled in designated areas.

32.-34. Mulching, Seeding & Fertilizing:

Quantities may be adjusted on actual disturbed areas. Multiple mobilizations may be necessary to complete the work. See Tabulation on Sheet C.06 for locations and breakdowns of quantities.

The Stabilized Seeding is intended for a nurse crop until the Native Seeding can establish.

35.-36. Silt Fence Items:

See Tabulations of Silt Fence on Sheet C.06. The linear feet of estimated fence are tabulated; installation and payment will be based on field conditions.

Silt Fence: The tabulation includes estimated locations for placement of Silt Fence to address possible erosion during construction. Verify the specific locations with the Engineer prior to beginning placement. Bid item includes 25% additional quantity for field adjustments and replacements. All Silt Fences along discharge areas shall be installed prior to the starting of any work that will disturb the existing vegetation.

Multiple mobilizations may be necessary to complete the erosion control work.

37. Sediment Control Device:

This item is included for areas that may not be accessible for Silt Fence installation or additional areas deemed necessary during staging & construction. Verify the specific locations with the Engineer prior to beginning placement.

38.-39. Erosion Control Mobilizations:

The contractor shall furnish the Engineer an initial ECIP for accomplishment of temporary and permanent erosion and sediment control.

GENERAL NOTES

This design is for a 140' x 44'-6" Continuous Concrete Slab Bridge at a 0° Skew on 230th Avenue over the Lower Gar Lake Outlet in Dickinson County, Iowa.

Minimum clear distance from face of concrete to near reinforcing bar is to be 2" unless otherwise noted or shown.

Access shall be maintained to individual properties during construction. Any costs for this work shall be included in the price bid for Traffic Control.

Dickinson County will provide the Construction Survey for the Project as per Section 2526. The Contractor is responsible for conducting an independent check of all construction stakes placed for the Project. This check shall be sufficient to understand the placement and intent of the stakes. Civil 3D electronic files will be available for the Contractors use as needed. The Contractor may need to modify the data for their use.

The Contractor shall determine the location of all existing utilities before commencing work. Should any utilities be found, they shall be protected in place and the Engineer immediately notified. The Contractor shall be fully responsible for any and all damages, which might be occasioned by the Contractors failure to locate and preserve any and all utilities. No claims for additional compensation will be allowed to the Contractor for interference, or delay for utility work. Coordination with electrical power companies may be required for clearances of construction equipment.

DESIGN FOR			
140' x 44' CONTINUOUS CONCRETE SLAB BRIDGE			
STA. 47+00		0° SKEW	
INTEGRAL ABUTMENTS	42'-6"	END SPANS	55'-0" CENTER SPAN
J44-14 BRIDGE STANDARDS			
DICKINSON COUNTY			

STANDARD ROAD PLANS

105-4
10-18-11

The following Standard Road Plans apply to construction work on this project.

Number	Date	Title
BR-205	10/15/2024	Double Reinforced 12" Approach (Slab Bridge)
DR-306	10/17/2023	Precast Concrete Headwall for Subdrain Outlets
EC-201	10/18/2022	Silt Fence
EC-202	10/21/2014	Floating Silt Curtain
EC-204	10/15/2024	Perimeter and Slope Sediment Control Devices
EW-202	4/19/2016	Bridge Berm Grading without Recoverable Slope (Non-Bamroof Section)
EW-401	10/20/2015	Temporary Stream Crossing, Causeway, or Equipment Pad
EW-501	10/17/2023	Rural Entrance
PM-110	10/15/2024	Line Types
PV-101	04/15/2025	Joints
SW-501	04/21/2020	Single Grate Intake
SW-514	04/17/2018	Boxout for Grate Intakes
SW-603	10/16/2018	Castings for Grate Intakes
TC-252	4/21/2020	Routes Closed to Traffic

BRIDGE STANDARDS

(May be obtained at <https://erl.iowadot.gov/>) (Standard Bridge Plans)

Standard	Date Issued	Latest Revision	TITLE
J44-01-14	JULY, 2014	MARCH, 2016	INDEX SHEET AND GENERAL NOTES
J44-16-14	JULY, 2014	AUG., 2020	SUPERSTRUCTURE DETAILS 140'-0 BRIDGE
J44-17-14	JULY, 2014	APRIL, 2016	SUPERSTRUCTURE DETAILS 140'-0 BRIDGE
J44-20-14	JULY, 2014	AUG., 2020	SUPERSTRUCTURE DETAILS ALL BRIDGES
J44-21-14	JULY, 2014	AUG., 2020	SUPERSTRUCTURE DETAILS ALL BRIDGES 0° SKEW
J44-25-14	JULY, 2014		MONOLITHIC PIER CAP DETAILS ALL BRIDGES
J44-26-14	JULY, 2014		MONOLITHIC PIER CAP DETAILS ALL BRIDGES
J44-39-14	JULY, 2014	MARCH, 2016	ABUTMENT DETAILS 0° SKEW - STEEL PILING
J44-44-14	JULY, 2014		ABUTMENT DETAILS STEEL PILING
J44-48-14	JULY, 2014	AUG., 2020	OPEN RAIL DETAILS (TL-4)
J44-49-14	JULY, 2014		OPEN RAIL DETAILS (TL-4)
J44-50-14	JULY, 2014	MARCH, 2016	SUBDRAIN DETAILS
J44-51-14	JULY, 2014	AUG., 2020	WING ARMORING DETAILS
J44-52-14	JULY, 2014	SEPT., 2016	ABUTMENT BACKFILL DETAILS 0° SKEWS
P10L	JAN., 2009	NOV., 2023	LRFD TRESTLE PILE BENTS - P10L

DESIGN FOR
140' x 44' CONTINUOUS CONCRETE SLAB BRIDGE
STA. 47+00 0° SKEW
INTEGRAL ABUTMENTS 42'-6 END SPANS 55'-0 CENTER SPAN
J44-14 BRIDGE STANDARDS
DICKINSON COUNTY

EARTHWORK TABULATION												
	Exc., Class 10 Roadway & Borrow				Topsoil	Class 10, Channel			Class 20 Exc.		Class 21 Exc.	
	CUT (C.Y.)	F+40% (C.Y.)	Waste (+) / Borrow (-) (C.Y.)	PAY QUANTITY (C.Y.)	PAY QUANTITY (C.Y.)	CUT (C.Y.)	WASTE * (C.Y.)	PAY QUANTITY (C.Y.)	CUT Abutment (C.Y.)	PAY QUANTITY (C.Y.)	CUT Piers / Stream (C.Y.)	PAY QUANTITY (C.Y.)
South Side of Bridge	406	283	123	406	64				39	39		
North Side of Bridge	630	635	(5)	630	163				87	87		
TOTAL	1,036	918	118	1,036	227	1,619	1,619	1,619	126	126	281	281

* Waste (Estimated): Assumes some material not suitable and be wasted off site. Does not include material not used for Roadway Borrow

TABULATION OF P.C.C. PAVEMENT											
Location Sta. to Sta.		Description	Type	Length (L.F.)	Width (L.F.)	Thickness (Inches)	Pavement Area (Square Yard)	Pavement Removal (Square Yards)	Modified Subbase (Cubic Yards)	Concrete Quantity (Cubic Yard)	
South Side	44+45	44+65	Mainline	P.C.C. Paving	20.00	22	8	48.89	48.89	11	
South Side	44+65	44+75	Mainline / Parking	P.C.C. Paving	10.00	27.7	8	30.78	30.78	7	
South Side	44+75	45+57.6	Mainline / Parking	P.C.C. Paving	82.60	33.5	8	307.46	307.46	68	
	45+57.6	48+42.4	Bridge & Approaches					759.94	651.0 *	-	
North Side	48+42.4	49+50	Mainline	P.C.C. Paving	107.60	22	8	263.02	263.02	58	
GRAND TOTAL								650.150	1,410.090	779.5	144

* Included in BR-205

BRIDGE APPROACH SECTION															
Refer to BR-205															
* Not a bid item															
Location		Approach Pavement							Subdrain					Remarks	
Bridge Station	End	Skew	Thickness	Pay Length	Non-Reinf. Pavement Area	Single-Reinf. Pavement Area	Double-Reinf. Pavement Area	Fixed or Movable Abutment	Perforated Subdrain 4"	Subdrain Outlet		Porous Backfill	Modified Subbase		Polymer Grid
										Degrees	Inches				
47+00.0	South	0°	12	71.75	153.55	103.3	146.75	M	52	45+67.56	Lt	1.5	320.6	420	Tie to existing curb & gutter.
47+00.0	North	0°	12	71.75	157.23	104.82	146.75	M	52	48+32.44	Lt	1.5	330.3	441	

DESIGN FOR
 140' x 44' CONTINUOUS CONCRETE SLAB BRIDGE
 STA. 47+00 0° SKEW
 INTEGRAL ABUTMENTS 42'-6" END SPANS 55'-0" CENTER SPAN
 J44-14 BRIDGE STANDARDS
 DICKINSON COUNTY

STRUCTURAL CONCRETE, REINFORCING, STEEL PILING TABULATION

LOCATION	Structural Concrete		Reinforcing Steel		Reinforcing Steel Epoxy Coated		Reinforcing Steel Stainless Steel		Steel Piling		
	Notes	(CY)	Notes	(LBS.)	Notes	(LBS.)	Notes	(LBS.)	Type	Notes	(L.F.)
South Abutment		15.7				2,359			HP10 x 42	9 @ 60'	540
South Pier	Cap included below	30.3		2,206	Included Below				HP12 x 53	17 @ 60'	1,020
Superstructure Includes:		490.6				105,458					
Abutment Wings	4 @ 0.68 C.Y.										
North Pier	Cap included above	30.3		2,206	Included Above				HP12 x 53	17 @ 60'	1,020
North Abutment		15.7				2,359			HP10 x 42	9 @ 60'	540
Conc. Open Rail TL-4	2 @ 12.2 C.Y. *	24.4*			2 @ 2,976.5 Lbs.	5,953	2 @ 1,552 Lbs.	3,104			
Open Rail End Section	4 @ 0.687 C.Y. *	2.8*			Included Above						
TOTALS	-	609.8	-	4,412	-	116,129	-	3,104	HP10 x 42	1,080	3,120
* - Not a Bid Item	Bid Quantity	582.6							HP12 x 53	2,040	

DELIVERY AND STOCKPILING

Item Description	Quantity	Units	Delivery Location	Address
58"x 36" x 60' Concrete Pipe	480	LF	East Milford Pit	2246 220th Street, Milford, Iowa
58"x 36" x 60' Concrete Aprons	16	Each	East Milford Pit	2246 220th Street, Milford, Iowa
12'x 5'x 50' Precast Conc. Box Culvert	50	LF	East Milford Pit	2246 220th Street, Milford, Iowa
14'x 4' Precast Conc. Box Culvert	128	LF	East Milford Pit	2246 220th Street, Milford, Iowa
12'x 5' Precast Conc. Box End Sections	2	Each	East Milford Pit	2246 220th Street, Milford, Iowa
14'x 4' Precast Conc. Box End Sections	4	Each	East Milford Pit	2246 220th Street, Milford, Iowa
Removed Pavement	1410	S.Y.	East Milford Pit	2246 220th Street, Milford, Iowa
Unsuitable Excavation (Class 10, 20, 21 & 22)	Unknown	C.Y.	East Milford Pit	2246 220th Street, Milford, Iowa

TABULATION OF SILT FENCE

STATION	TO	STATION	SIDE	LIN. FT.	REMARKS
46+00		46+33	Lt.	45	
45+00		45+50	Rt.	55	
45+58		45+85	Rt.	30	
45+72		45+85	Rt.	20	
47+75		48+45	Lt.	70	
48+75			Lt.	20	Across Ditch North side Entrance
47+65		48+05	Rt.	50	
48+50			Rt.	20	Across Ditch North side Entrance
				310	Subtotal
				1.25	Adjustment Factor
				390	BID QUANTITY SILT FENCE

NOTE: ABOVE LOCATIONS AND LENGTHS ARE ESTIMATED. ACTUAL LOCATIONS AND LENGTHS WILL BE DETERMINED IN FIELD. MULTIPLE MOBILIZATIONS MAY BE REQUIRED TO COMPLETE THE WORK.

REVTMENT, FABRIC & EROSION STONE TABULATION

See Sheet V.01 for details

Location	Area (Sq. Ft.)	Engineering Fabric (Sq. Yd.)	Revetment (Tons)	Erosion Stone (Tons)	Remarks
South Abutment Slope	1,041.00	116.00	82.00		
South Abutment Wing / Berm	211.00	23.00		13.00	
North Abutment Slope / Berm	1,040.00	116.00		12.00	
North Abutment Wing	194.00	22.00	82.00		
TOTALS	9,054.00	277.00	164.00	25.00	

TABULATION OF SEEDING DETAILS

LOCATION		Mulching (Acres)	Native Seeding (Acres)	Stabilizing Crop-Seeding & Fertilizing (Acres)	Remarks
Station to Station					
44+45 Lt.	46+29 Lt.	0.1	0.1	0.1	South Side Bridge
46+24 Rt.	46+29 Rt.	0.05	0.05	0.05	South Side Bridge
47+70 Lt.	49+50 Lt.	0.15	0.15	0.15	North Side Bridge
47+70 Rt.	49+50 Rt.	0.15	0.15	0.15	North Side Bridge
		0.45	0.45	0.45	

TABULATION OF FLOATING SILT FENCE

STATION	TO	STATION	SIDE	LIN. FT.	REMARKS
46+00		47+65	Rt.	200	East Side
46+30		47+75	Lt.	200	West Side
				400	BID QUANTITY SILT FENCE

NOTE: ABOVE LOCATIONS AND LENGTHS ARE ESTIMATED. ACTUAL LOCATIONS AND LENGTHS WILL BE DETERMINED IN FIELD. MULTIPLE MOBILIZATIONS MAY BE REQUIRED TO COMPLETE THE WORK.

DESIGN FOR
 140' x 44' CONTINUOUS CONCRETE SLAB BRIDGE
 STA. 47+00 0° SKEW
 INTEGRAL ABUTMENTS 42'-6" END SPANS 55'-0" CENTER SPAN
 J44-14 BRIDGE STANDARDS
 DICKINSON COUNTY

GRAPHIC SCALE

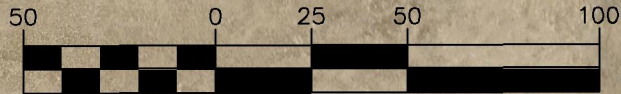

(IN FEET)

1 inch = 50 ft.

MILFORD TWP.
Sec. 6, T98N, R36W

Sta. 47+00
Construct 140'-0" x 44'-0" Continuous Concrete Slab Bridge
0° Skew, P10L Type3 Full Encased Piling
HP10x42 Steel Pile Abutments
HP12x53 Steel Pile Piers

48+58 Drive Lt.
No Pipe
F&I 18"x 50' CMP
36' Top

Sta. 47+00 (REMOVE & DISPOSE)
(8) LINES 58" x 36" CONC. ARCH PIPE CULV.
(1) LINE 12' x 5' PRECAST BOX CULV. + 2 END SECTIONS
46+37 14'x4'x67' PRECAST BOX CULV. + 2 END SECTIONS
47+57 14'x4'x61' PRECAST BOX CULV. + 2 END SECTIONS

45+57.6
Begin BR-205

46+42.4
End BR-205

END PROJECT
49+50

BEGIN PROJECT
44+45

Sec. 5, T98N, R36W
MILFORD TWP.

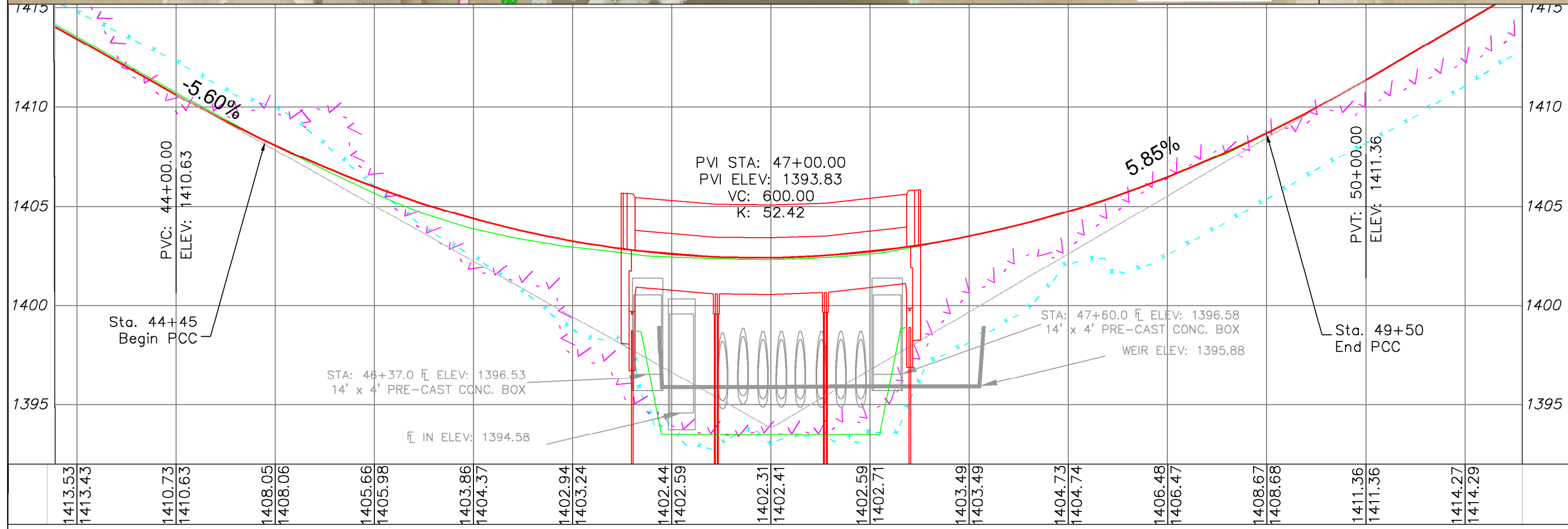

1413.53	1413.43	1410.73	1410.63	1408.05	1408.06	1405.66	1405.98	1403.86	1404.37	1402.94	1403.24	1402.44	1402.59	1402.31	1402.41	1402.59	1402.71	1403.49	1403.49	1404.73	1404.74	1406.48	1406.47	1408.67	1408.68	1411.36	1411.36	1414.27	1414.29
44+00		45+00		46+00		47+00		48+00		49+00		50+00		51+															

LOG OF EXPLORATORY BORING												Sheet 1 of 1				
		Job Number: G7380		Boring No.: S-1												
		Project: 230th Avenue Bridge		Boring Location: Dickinson Co., IA												
		Date Started: 5/14/24		Drill Type: Hollow Stem												
		Date Completed: 5/14/24		Ground Elev.: 1403.3												
Depth in Feet	Graphic Log	Sample Type	SOIL DESCRIPTION			USCS	Blow Counts SPT (N) Blows/Foot	Moisture Content, %	Dry Density (PCF)	% Saturation	Hand Penetrometer (TSF)	Unconfined Comp. Strength (TSF)	Liquid Limit %	Plastic Limit %	Plasticity Index %	Cone Penetrometer (Blows/1.34")
0-1	6-Inch Gravel Layer		FIRM SILTY CLAY, Dark Brown and Yellow Brown, Fill (Gravel/Cobble)				17-7-7 N= 14									
1-5	(Gravel)		STIFF SANDY CLAY, Dark Brown, Fill				4-3-3 N= 5									
5-10			CLAYEY SAND, Brownish Gray			SC	9-3-5 N= 8									
10-15			FINE SAND, Dark Gray Brown and Yellow Brown, Oxidized (Cobbles)			SP	8-8-8 N= 16									
15-20			FIRM GLACIAL CLAY, Dark Gray			CL	3-4-5 N= 9									
20-25							4-6-7 N= 13									
25-30			VERY FIRM GLACIAL CLAY, Dark Gray (Cobbles)			CL	6-8-10 N= 18									
30-35							19-13-18 N= 31									
35-40							5-10-11 N= 21									
40-45							9-9-10 N= 19									
45-50							9-13-18 N= 29									
50-55							6-12-14 N= 26									
55-60							10-10-13 N= 23									
60-65			GLACIAL MATERIAL, Dark Gray			CL	9-17-22 N= 39									
65-70							21-50-100 N= 150									
			END OF BORING AT 71.5 FEET FREE WATER WAS ENCOUNTERED AT 5.3 FEET AT TIME OF DRILLING													

NORTH ABUTMENT

LOG OF EXPLORATORY BORING												Sheet 1 of 1				
		Job Number: G7380		Boring No.: S-2												
		Project: 230th Avenue Bridge		Boring Location: Dickinson Co., IA												
		Date Started: 5/13/24		Drill Type: Hollow Stem												
		Date Completed: 5/13/24		Ground Elev.: 1402.6												
Depth in Feet	Graphic Log	Sample Type	SOIL DESCRIPTION			USCS	Blow Counts SPT (N) Blows/Foot	Moisture Content, %	Dry Density (PCF)	% Saturation	Hand Penetrometer (TSF)	Unconfined Comp. Strength (TSF)	Liquid Limit %	Plastic Limit %	Plasticity Index %	Cone Penetrometer (Blows/1.34")
0-1	6-Inch Gravel Layer		FIRM SILTY CLAY, Dark Brown, Fill				1-5-10 N= 15									
1-5	(Gravel)		CLAYEY SAND, Brownish Gray and Yellowish Orange, Fill				13-8-7 N= 15									
5-10			FIRM SILTY CLAY, Dark Brownish Gray, Fill (Cobbles)				21-40-40 N= 80									
10-15			GRAVELY SAND, Brownish Gray (Cobbles)			SW	4-18-18 N= 36									
15-20																
			END OF BORING AT 23 FEET DUE TO AUGER REFUSAL ON COBBLES/POSSIBLE BOULDERS FREE WATER WAS ENCOUNTERED AT 6.2 FEET AT TIME OF DRILLING													

NORTH PIER

Depth in Feet	Graphic Log	Sample Type	SOIL DESCRIPTION										USCS	Blow Counts SPT (N) Blows/Foot	Moisture Content, %	Dry Density (PCF)	% Saturation	Hand Penetrometer (TSF)	Unconfined Comp. Strength (TSF)	Liquid Limit %	Plastic Limit %	Plasticity Index %	Cone Penetrometer (Blows/1-3ft)					
0-5			12-Inch Gravel Layer											5-7-8														
5-6			FIRM SILTY CLAY, Dark Brown and Yellow Brown, Fill											N= 15														
6-9			CLAYEY SAND, Light Brown, Fill											6-4-5														
9-10			(Gravel)											N= 9														
10-15			GRAVELY SAND, Light Gray, Fill (Cobbles)											10-21-15														
15-16			COARSE SAND, Brownish Gray (Gravel)										SP	9-11-15														
16-20			FIRM SILTY GLACIAL CLAY, Dark Gray										CL	10-4-4														
20-25			FIRM GLACIAL CLAY, Dark Gray										CL	9-2-2														
25-30			FIRM GLACIAL CLAY, Dark Gray										CL	2-6-7														
30-35			VERY FIRM GLACIAL CLAY, Dark Gray (Gravel and Cobbles)										CL	4-10-10														
35-40			VERY FIRM GLACIAL CLAY, Dark Gray (Gravel/Cobble)										CL	4-10-10														
40-45			VERY FIRM GLACIAL CLAY, Dark Gray (Gravel/Cobble)										CL	4-10-10														
45-50			VERY FIRM GLACIAL CLAY, Dark Gray (Gravel/Cobble)										CL	4-9-10														
50-55			GLACIAL MATERIAL, Dark Gray										CL	32-30-20														
55-60			VERY FIRM GLACIAL CLAY, Dark Gray										CL	16-12-12														
60-65			VERY FIRM GLACIAL CLAY, Dark Gray										CL	14-12-14														
65-88.5			END OF BORING AT 88.5 FEET FREE WATER WAS ENCOUNTERED AT 11 FEET AT TIME OF DRILLING											N= 26														

SOUTH PIER

Depth in Feet	Graphic Log	Sample Type	SOIL DESCRIPTION										USCS	Blow Counts SPT (N) Blows/Foot	Moisture Content, %	Dry Density (PCF)	% Saturation	Hand Penetrometer (TSF)	Unconfined Comp. Strength (TSF)	Liquid Limit %	Plastic Limit %	Plasticity Index %	Cone Penetrometer (Blows/1-3ft)					
0-6			6-Inch Gravel Layer											2-2-3														
6-8			SILTY SAND, Yellowish Orange, Fill											N= 5														
8-10			COARSE SAND, Light Brownish Gray (Gravel/Cobbles)										SP	1-1-2														
10-17			FINE SAND, Brownish Gray										SP	7-6-11														
17-20			FIRM SILTY GLACIAL CLAY, Dark Gray										CL	0-3-5														
20-25			FIRM SILTY GLACIAL CLAY, Dark Gray										CL	N= 8														
25-30			VERY FIRM GLACIAL CLAY, Dark Gray										CL	1-3-5														
30-35			VERY FIRM GLACIAL CLAY, Dark Gray										CL	4-7-11														
35-40			VERY FIRM GLACIAL CLAY, Dark Gray										CL	N= 18														
40-45			VERY FIRM GLACIAL CLAY, Dark Gray (Gravel)										CL	6-10-11														
45-50			VERY FIRM GLACIAL CLAY, Dark Gray (Gravel)										CL	N= 21														
50-55			VERY FIRM GLACIAL CLAY, Dark Gray (Gravel)										CL	6-10-14														
55-60			VERY FIRM GLACIAL CLAY, Dark Gray (Gravel)										CL	N= 24														
60-65			VERY FIRM GLACIAL CLAY, Dark Gray (Gravel)										CL	6-10-14														
65-70			VERY FIRM GLACIAL CLAY, Dark Gray (Gravel)										CL	8-10-16														
70-75			VERY FIRM GLACIAL CLAY, Dark Gray										CL	N= 26														
75-80			GLACIAL MATERIAL, Dark Gray										CL	7-10-16														
80-85			GLACIAL MATERIAL, Dark Gray										CL	7-13-17														
85-90			GLACIAL MATERIAL, Dark Gray										CL	N= 30														
90-95			GLACIAL MATERIAL, Dark Gray										CL	8-18-20														
95-100			GLACIAL MATERIAL, Dark Gray										CL	N= 38														
100-105			GLACIAL MATERIAL, Dark Gray										CL	10-20-24														
105-110			GLACIAL MATERIAL, Dark Gray										CL	N= 44														
110-120			VERY FIRM GLACIAL CLAY, Dark Gray										CL	5-10-10														
120-170			END OF BORING AT 70 FEET FREE WATER WAS ENCOUNTERED AT 4 FEET AT TIME OF DRILLING											N= 20														

SOUTH ABUTMENT

North Abutment

Pile Design Notes: LRFD contract length and resistance -- E818

The Contract Length of 60 Feet for the North Abutment Sta. 47+70.00 Piles is based on a Cohesive Soil Classification, a Total Factored Axial Load per pile (PU) of 97 Kips, and a Geotechnical Resistance Factor (PHI) of 0.6.

The Nominal Axial Bearing Resistance for Construction Control was determined from a Cohesive Soil Classification and a Geotechnical Resistance Factor (PHI) of 0.55. Piles are assumed to be driven from a Start Elevation at the Bottom of Prebore Elev. 1386.88.

PILE DRIVING NOTE: LRFD driving and construction control -- E819

The Required Nominal Axial Bearing Resistance for the North Abutment Sta. 47+70.00 Piles is 88 Tons at End of Drive (EOD) or Retap. The pile contract length shall be driven as per plan unless piles reach refusal. Construction control requires a Modified Iowa IDOT ENR Formula.

North Pier

Pile Design Notes: LRFD contract length and resistance -- E718

The Contract Length of 60 Feet for the North Pier Sta. 47+27.50 Piles is based on a Cohesive Soil Classification, a Total Factored Axial Load per pile (PU) of 99 Kips, and a Geotechnical Resistance Factor (PHI) of 0.6.

The Nominal Axial Bearing Resistance for Construction Control was determined from a Cohesive Soil Classification and a Geotechnical Resistance Factor (PHI) of 0.55. Piles are assumed to be driven from a Start Elevation at the Bottom of Encasement Elev. 1390.50.

PILE DRIVING NOTE: LRFD driving and construction control -- E719

The Required Nominal Axial Bearing Resistance for the North Pier Sta. 47+27.50 Piles is 90 Tons at End of Drive (EOD) or Retap. The pile contract length shall be driven as per plan unless piles reach refusal. Construction control requires a Modified Iowa IDOT ENR Formula.

South Pier

Pile Design Notes: LRFD contract length and resistance -- E718

The Contract Length of 60 Feet for the South Pier Sta. 46+72.50 Piles is based on a Cohesive Soil Classification, a Total Factored Axial Load per pile (PU) of 99 Kips, and a Geotechnical Resistance Factor (PHI) of 0.6.

The Nominal Axial Bearing Resistance for Construction Control was determined from a Cohesive Soil Classification and a Geotechnical Resistance Factor (PHI) of 0.55. Piles are assumed to be driven from a Start Elevation at the Bottom of Encasement Elev. 1390.50.

PILE DRIVING NOTE: LRFD driving and construction control -- E719

The Required Nominal Axial Bearing Resistance for the South Pier Sta. 46+72.50 Piles is 90 Tons at End of Drive (EOD) or Retap. The pile contract length shall be driven as per plan unless piles reach refusal. Construction control requires a Modified Iowa IDOT ENR Formula.

South Abutment

Pile Design Notes: LRFD contract length and resistance -- E818

The Contract Length of 60 Feet for the South Abutment Sta. 46+30.00 Piles is based on a Cohesive Soil Classification, a Total Factored Axial Load per pile (PU) of 97 Kips, and a Geotechnical Resistance Factor (PHI) of 0.6.

The Nominal Axial Bearing Resistance for Construction Control was determined from a Cohesive Soil Classification and a Geotechnical Resistance Factor (PHI) of 0.55. Piles are assumed to be driven from a Start Elevation at the Bottom of Prebore Elev. 1386.71.

PILE DRIVING NOTE: LRFD driving and construction control -- E819

The Required Nominal Axial Bearing Resistance for the South Abutment Sta. 46+30.00 Piles is 88 Tons at End of Drive (EOD) or Retap. The pile contract length shall be driven as per plan unless piles reach refusal. Construction control requires a Modified Iowa IDOT ENR Formula.

Sounding and test boring data shown on plans were accumulated for designing and estimating purposes. Their appearance on the plan does not constitute a guarantee that conditions other than those indicated will not be encountered.

This Project uses the Load and Resistance Factor Design (LRFD) methodology for determining pile contract length and nominal axial bearing resistance. Nominal axial bearing resistances will be larger than bearing values in the past, but construction control blow counts will be approximately the same. Construction control requires a Modified Iowa IDOT ENR Formula.

Due to cobbles and or possible boulders being encountered in the soil borings at varying depths, Cast-in-One-Piece Steel Pile Points are required for all piles in accordance with Article 4167.02 of the current Standard Specifications and Materials I.M. 468.

DESIGN FOR			
140' x 44' CONTINUOUS CONCRETE SLAB BRIDGE			
STA. 47+00		0° SKEW	
INTEGRAL ABUTMENTS	42'-6"	END SPANS	55'-0" CENTER SPAN
PILING NOTES			
DICKINSON COUNTY			

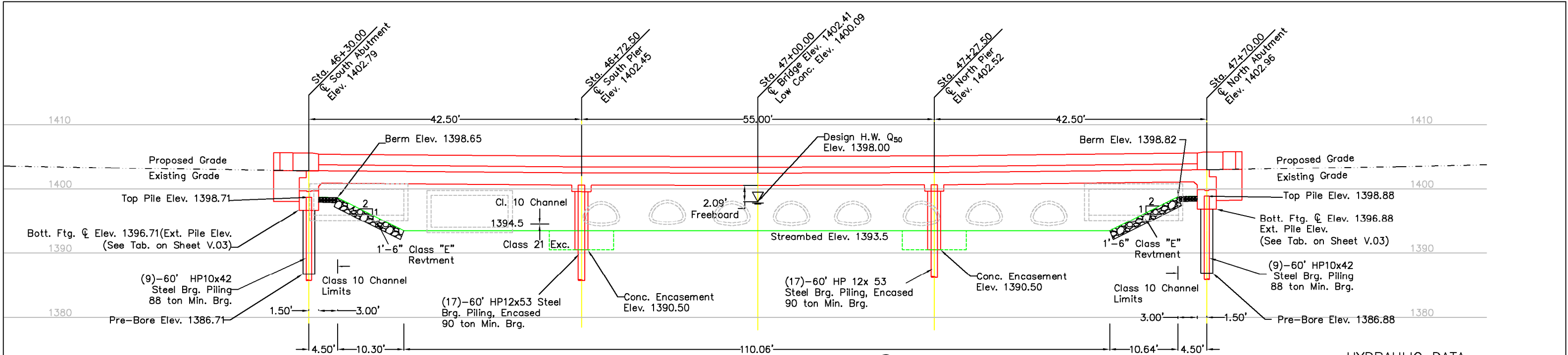

LONGITUDINAL SECTION ALONG CL ROADWAY

Not to Scale

HYDRAULIC DATA

DRAINAGE AREA	125 SQ.MI.
DESIGN DISCHARGE Q_{50}	1,220 C.F.S.
DESIGN HIGHWATER	1398.00
BRIDGE WATERWAY AREA Q_{50}	517.8 SQ.FT.
DESIGN VELOCITY	2.4 F.P.S.
DESIGN STAGES	
Q_{10}	726 C.F.S. STAGE 1396.90
Q_{50}	1,220 C.F.S. STAGE 1398.00
Q_{100}	1,538 C.F.S. STAGE 1398.68
Q_{500}	2,372 C.F.S. STAGE 1400.78
EXTREME H.W.	1399.96 ft. DATE SPRING 1993

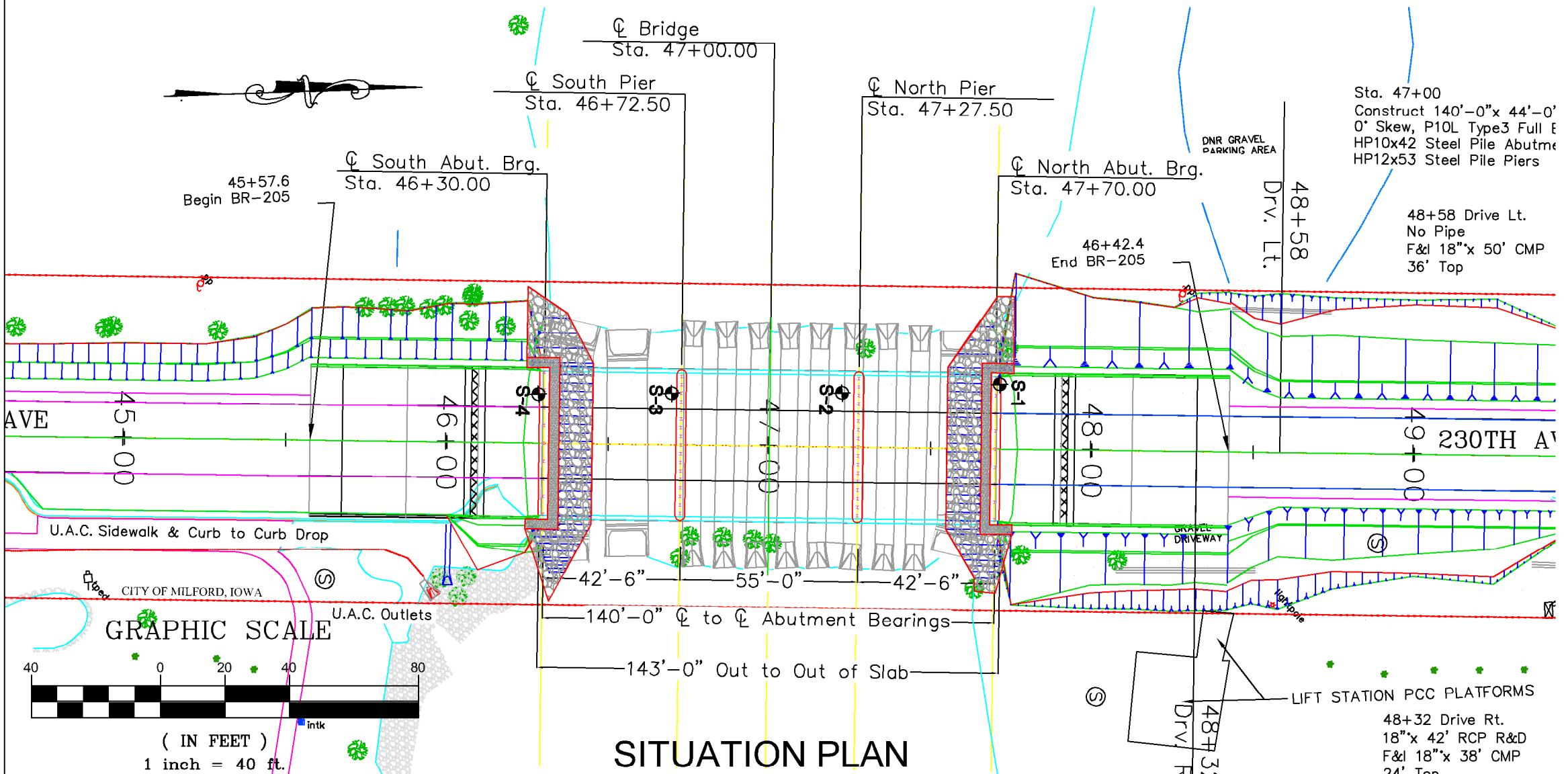

SITUATION PLAN

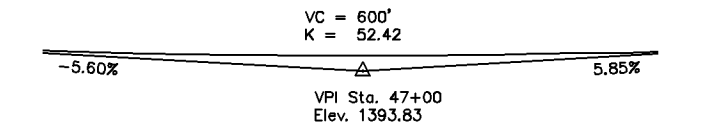

PROPOSED GRADELINE

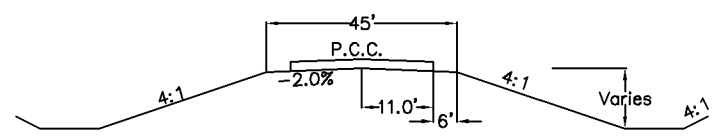

TYPICAL SECTION

LOCATION:
230th Avenue over Lower Gar Outlet
Sections 5 & 6, T98N, R36W
Milford Twp., Dickinson County, Iowa

DESIGN FOR	
140' x 44' CONTINUOUS CONCRETE SLAB BRIDGE	STA. 47+00
INTEGRAL ABUTMENTS	42'-6" END SPANS 55'-0" CENTER SPAN
P10L TYPE 3 PILING-FULL ENCASED	MONOLITHIC PIER CAPS
J44-14	DICKINSON COUNTY

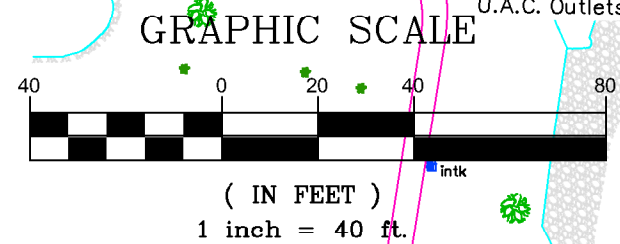

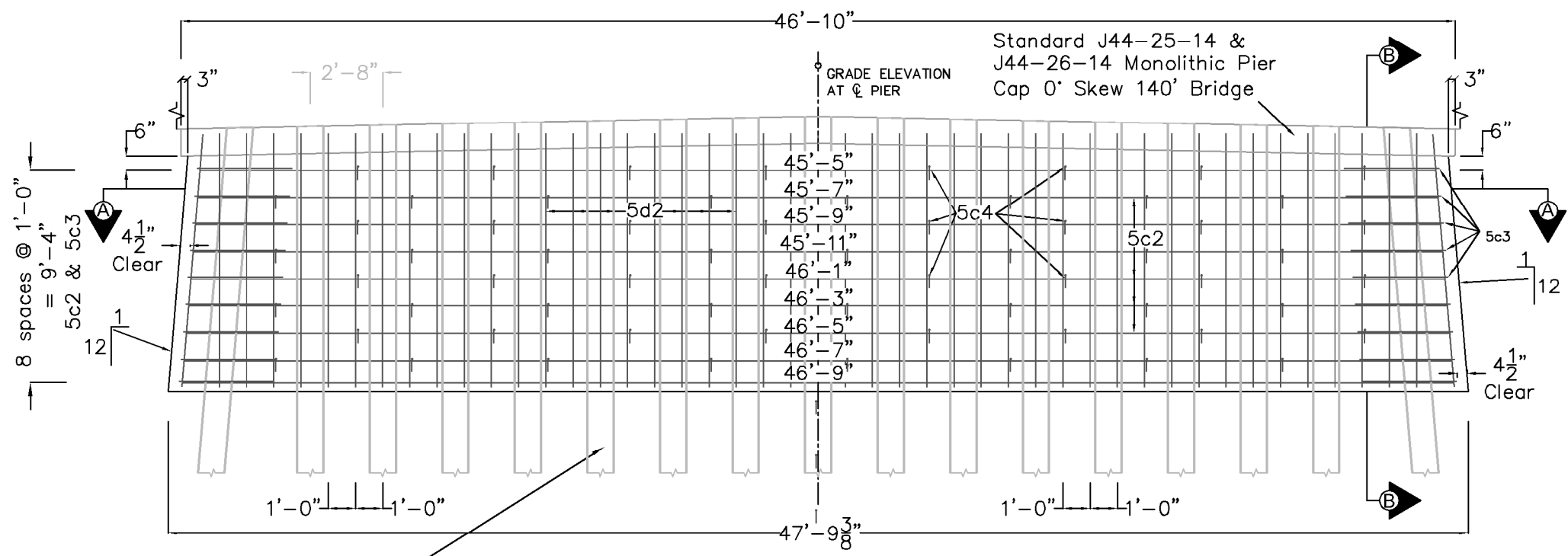

ESTIMATED QUANTITIES PER PIER		
ITEM	UNIT	TOTAL
Structural Concrete (Encasement)	C.Y.	30.30
Reinforcing Steel	Lbs.	2,206
HP 12x53 Steel Bearing Piles	L.F.	1,020
Excavation, Class 21 (Both Piers)	C.Y.	281

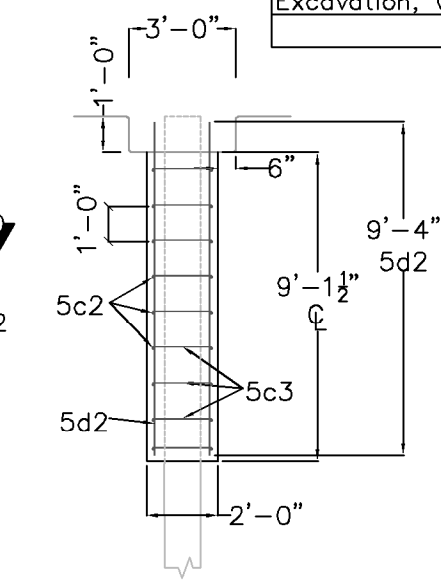

- PIER NOTES:**
- Pier Cap, Standard J44-25-14 & J44-26-14, 17 Pile Bent, 0° Skew, 140' Bridge. Cap Steel and reinforcing not detailed, see Standards.
 - Encasements are similar in design.
 - All exposed corners of 90° or sharper to be filleted 3/4"
 - Minimum clear distance from face of concrete to near reinforcing bar is to be 2" unless noted.
 - Reinforcing steel to be securely wired in place before concrete is placed.
 - Design Bearing for Pier Piles is 90 Ton per pile.
 - P10A cap steel not tabulated.

SECTION B-B

PIER CONCRETE ENCASEMENT

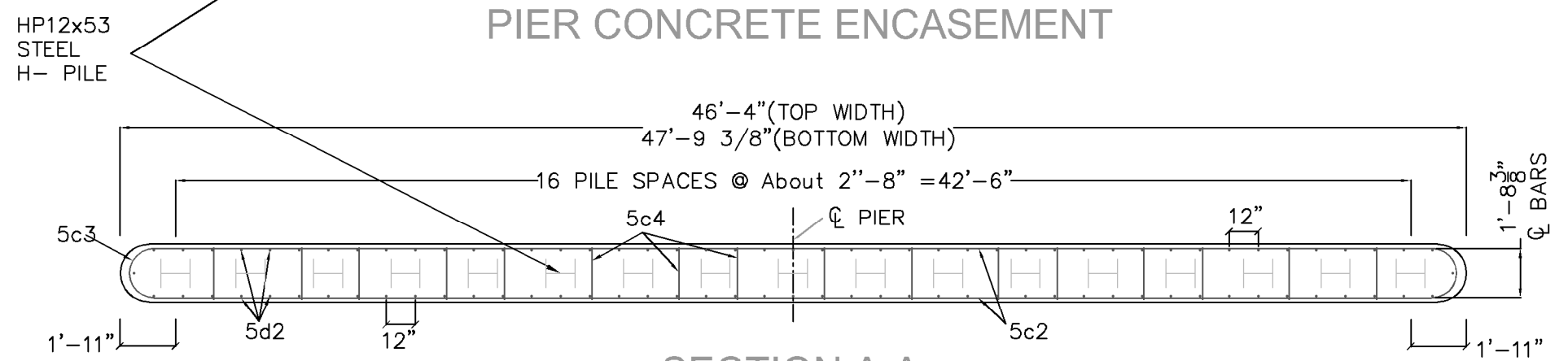

SECTION A-A

REINFORCING BAR LIST - PER PILE ENCASEMENT						
BAR	LOCATION	SHAPE	SPACING	NO.	LENGTH	WEIGHT
5c2	Horizontal	—	1'-0"	18	Shown	865
5c3	Horiz. Ends	U	1'-0"	18	8'-0"	150
5c4	Horiz. Ties	C	Shown-Alt.	64	4'-5"	295
5d2	Vertical	—	1'-0"	92	9'-4"	896
TOTAL						2,206

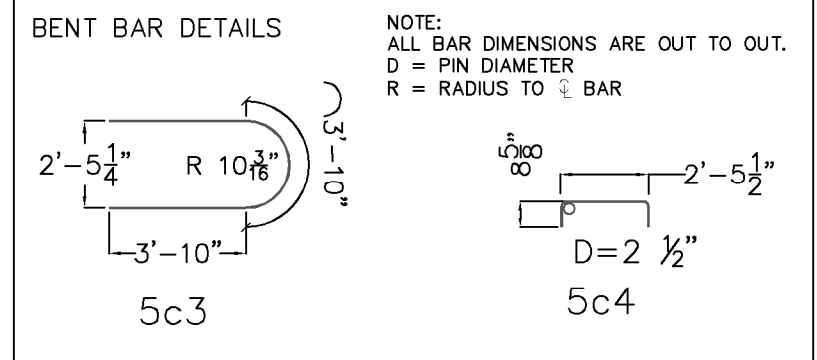

DESIGN FOR
 140' x 44' CONTINUOUS CONCRETE SLAB BRIDGE
 STA. 47+00 0° SKEW
 INTEGRAL ABUTMENTS 42'-6" END SPANS 55'-0" CENTER SPAN
 PIER ENCASEMENT DETAILS
 DICKINSON COUNTY

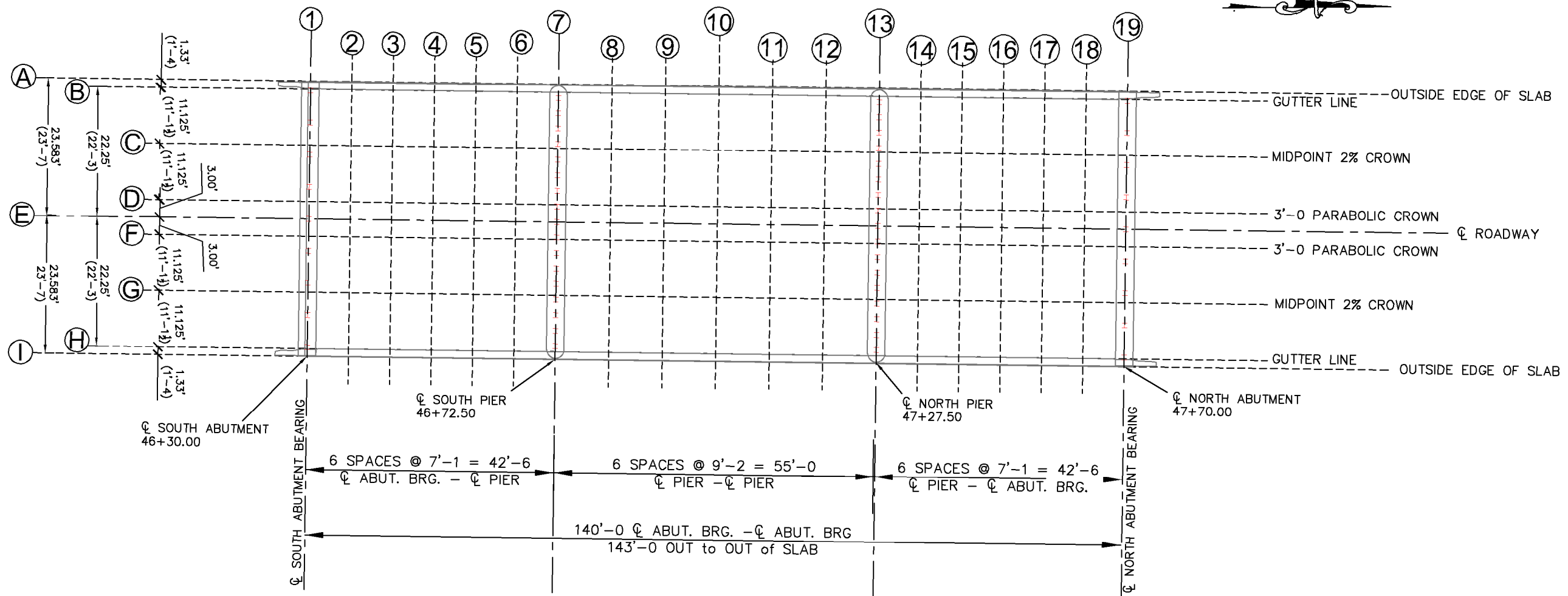

TOP OF SLAB ELEVATIONS

LOCATION	END OF WING	C.L. S. ABUT. BRG.	CL BRIDGE																	C.L. N. ABUT. BRG.	END OF WING		
			6 Spa. @ 7'-1 = 42'-6						C.L. SOUTH PIER	6 Spa. @ 9'-2 = 55'-0						C.L. NORTH PIER	6 Spa. @ 7'-1 = 42'-6						
			LINE 1	LINE 2	LINE 3	LINE 4	LINE 5	LINE 6		LINE 7	LINE 8	LINE 9	LINE 10	LINE 11	LINE 12		LINE 13	LINE 14	LINE 15			LINE 16	LINE 17
A	WEST OUTSIDE EDGE SLAB	1402.42	1402.35	1402.27	1402.20	1402.14	1402.09	1402.04	1402.01	1401.98	1401.97	1401.97	1401.99	1402.02	1402.08	1402.13	1402.19	1402.26	1402.34	1402.42	1402.52	1402.61	
B	WEST GUTTER LINE		1402.39	1402.31	1402.24	1402.17	1402.12	1402.08	1402.05	1402.02	1402.00	1402.01	1402.03	1402.06	1402.11	1402.16	1402.22	1402.29	1402.37	1402.46	1402.56		
C	MIDPOINT 2% CROWN		1402.61	1402.53	1402.45	1402.39	1402.34	1402.30	1402.26	1402.23	1402.22	1402.22	1402.24	1402.28	1402.33	1402.38	1402.44	1402.51	1402.59	1402.68	1402.78		
D	3' PARABOLIC CROWN		1402.76	1402.68	1402.61	1402.55	1402.50	1402.45	1402.42	1402.39	1402.38	1402.38	1402.40	1402.44	1402.49	1402.54	1402.60	1402.67	1402.75	1402.84	1402.93		
E	C.L. ROADWAY	1402.86	1402.79	1402.71	1402.64	1402.58	1402.53	1402.48	1402.45	1402.42	1402.41	1402.41	1402.43	1402.47	1402.52	1402.57	1402.63	1402.70	1402.78	1402.87	1402.97	1403.05	
F	3' PARABOLIC CROWN		1402.76	1402.68	1402.61	1402.55	1402.50	1402.45	1402.42	1402.39	1402.38	1402.38	1402.40	1402.44	1402.49	1402.54	1402.60	1402.67	1402.75	1402.84	1402.93		
G	MIDPOINT 2% CROWN		1402.61	1402.53	1402.45	1402.39	1402.34	1402.30	1402.26	1402.23	1402.22	1402.22	1402.24	1402.28	1402.33	1402.38	1402.44	1402.51	1402.59	1402.68	1402.78		
H	EAST GUTTER LINE		1402.39	1402.31	1402.24	1402.17	1402.12	1402.08	1402.05	1402.02	1402.00	1402.01	1402.03	1402.06	1402.11	1402.16	1402.22	1402.29	1402.37	1402.46	1402.56		
I	EAST OUTSIDE EDGE OF SLAB	1402.42	1402.35	1402.27	1402.20	1402.14	1402.09	1402.04	1402.01	1401.98	1401.97	1401.97	1401.99	1402.02	1402.08	1402.13	1402.19	1402.26	1402.34	1402.42	1402.52	1402.61	

Camber dimensions required for the anticipated dead load deflections have not been added to the elevations above. See below for form camber details.
 For floor elevations, subtract 1.875' (1'-10 1/2") from the elevations shown

FORM CAMBER	N/A	N/A	(5/16") 0.026	(1/2") 0.042	(1/2") 0.042	(5/16") 0.026	(1/8") 0.010	N/A	(7/16") 0.036	(13/16") 0.063	(1-3/16") 0.099	(13/16") 0.063	(7/16") 0.036	N/A	(1/8") 0.010	(5/16") 0.026	(1/2") 0.042	(1/2") 0.042	(5/16") 0.026	N/A	N/A
-------------	-----	-----	------------------	-----------------	-----------------	------------------	-----------------	-----	------------------	-------------------	--------------------	-------------------	------------------	-----	-----------------	------------------	-----------------	-----------------	------------------	-----	-----

DESIGN FOR
 140' x 44' CONTINUOUS CONCRETE SLAB BRIDGE
 STA. 47+00 0° SKEW
 INTEGRAL ABUTMENTS 42'-6" END SPANS 55'-0" CENTER SPAN
 TOP OF SLAB ELEVATIONS
 DICKINSON COUNTY

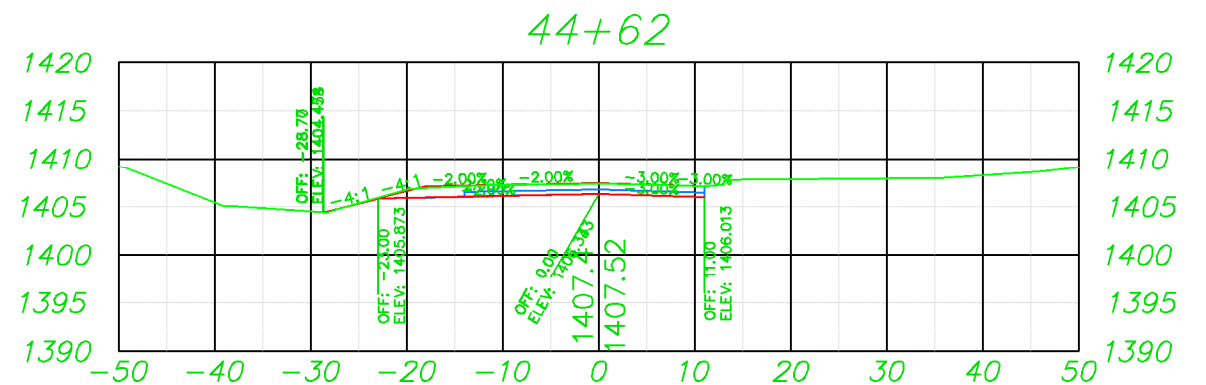
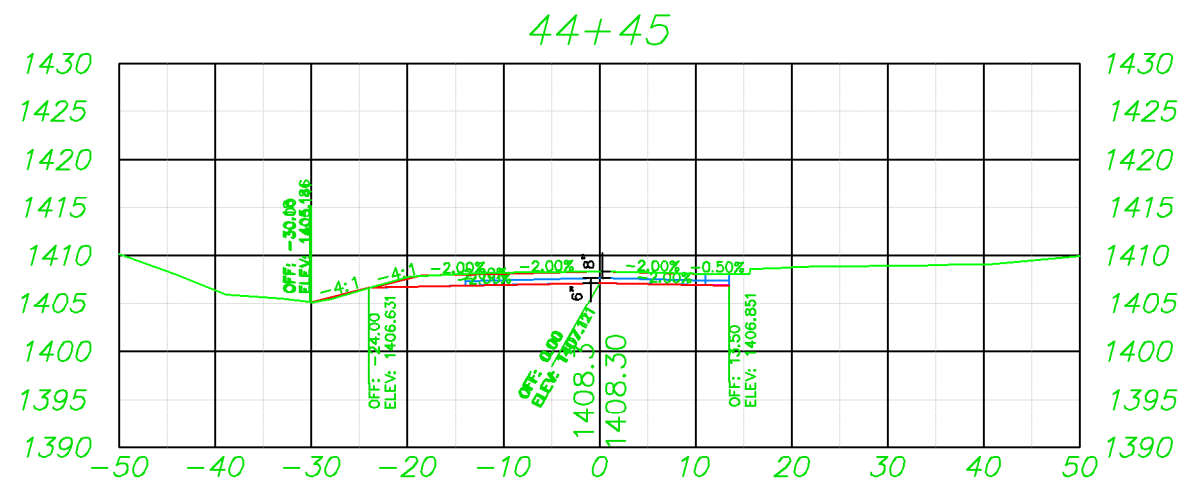
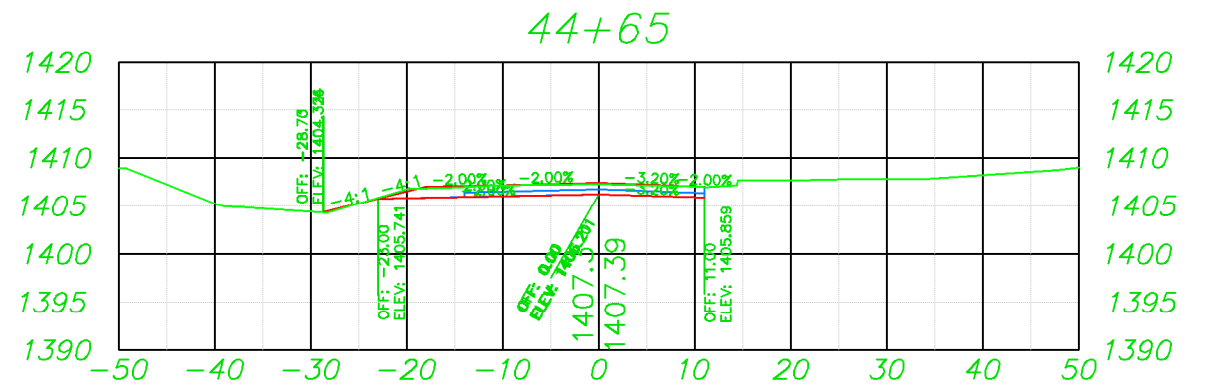
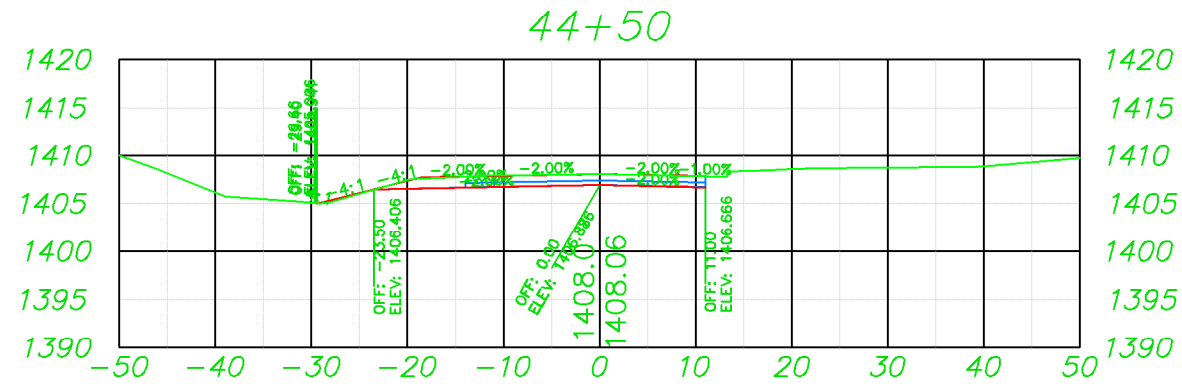
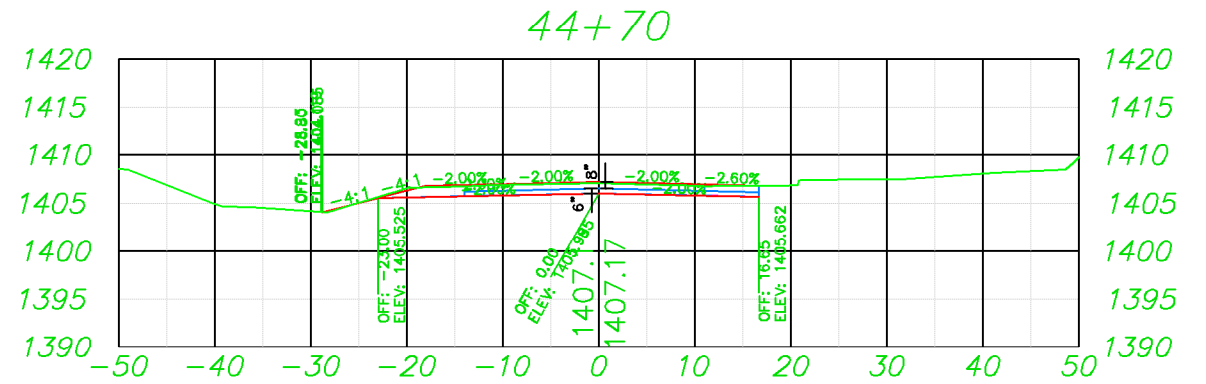
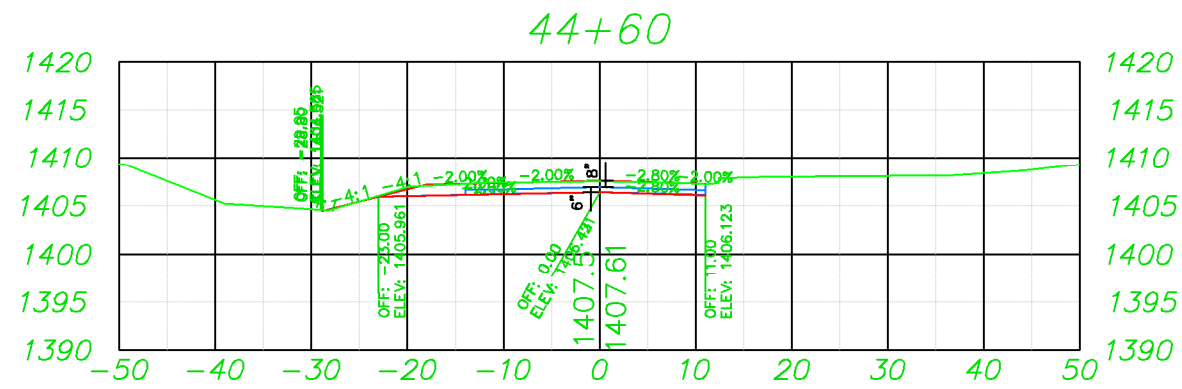

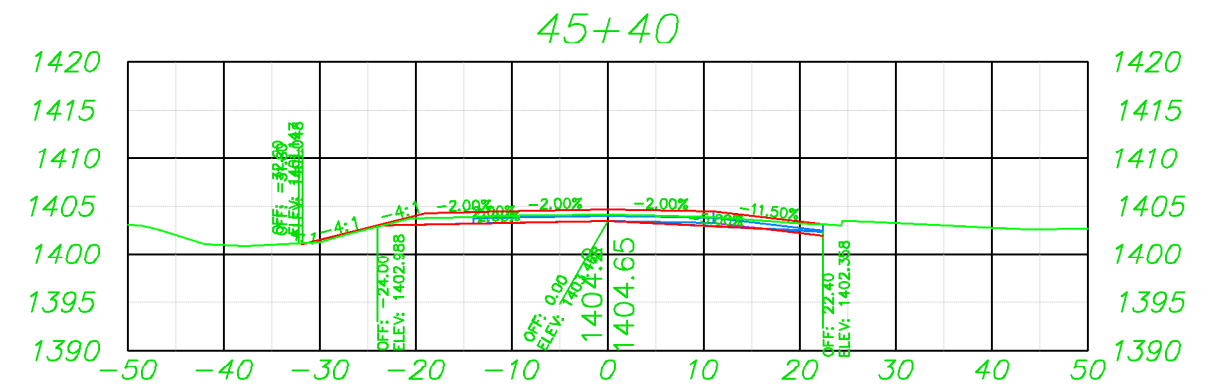
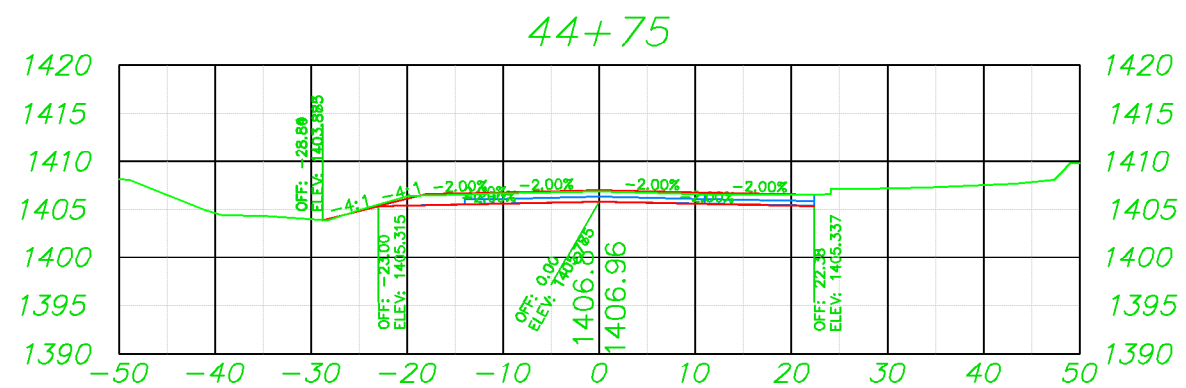
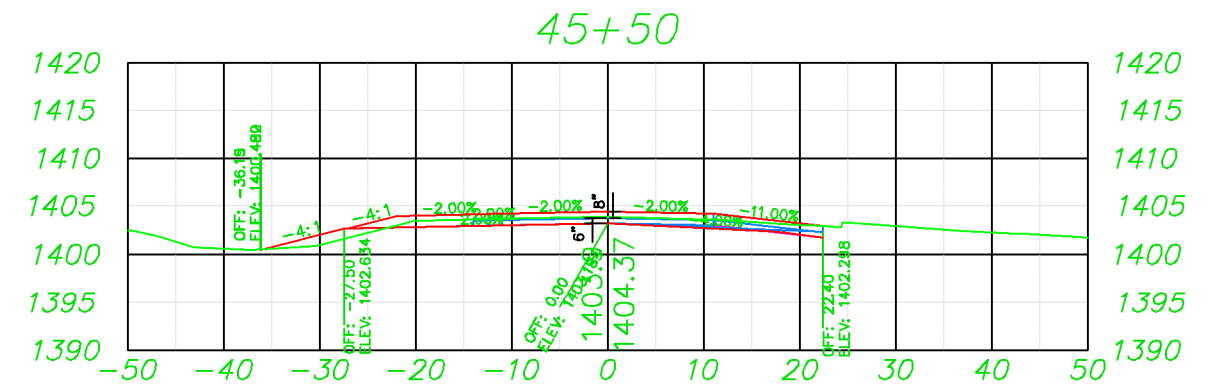
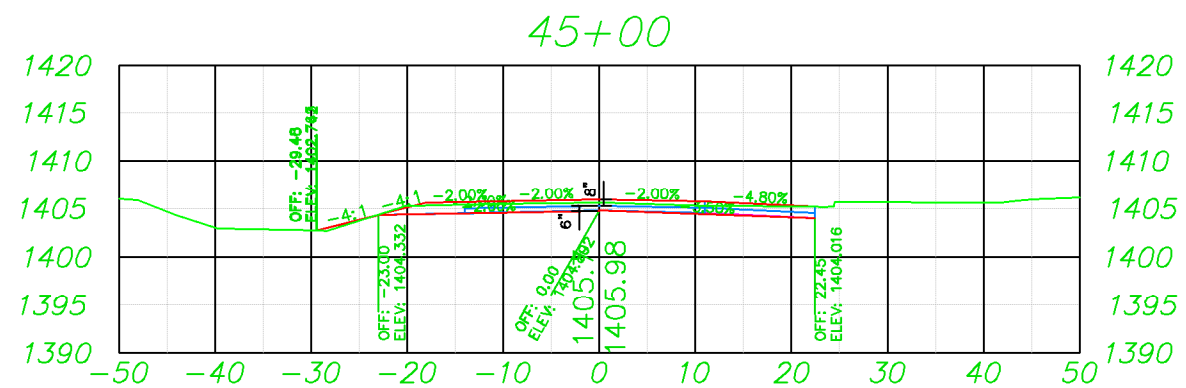
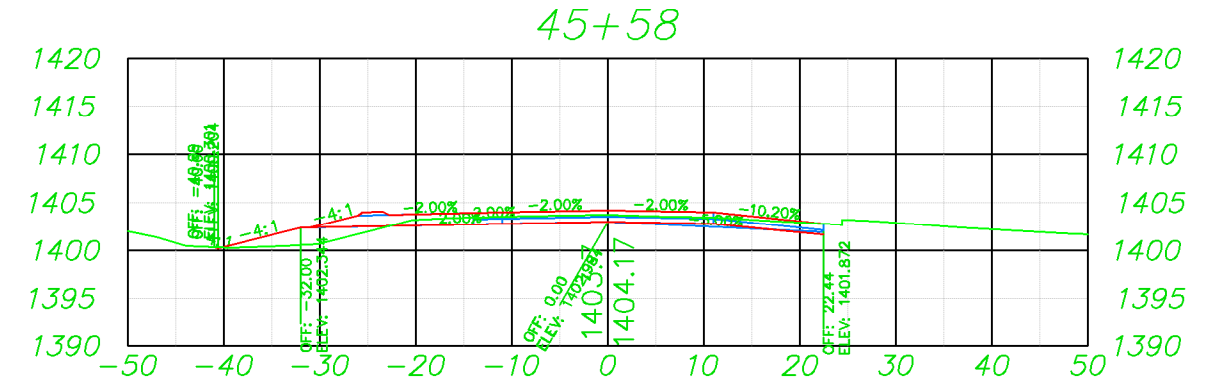
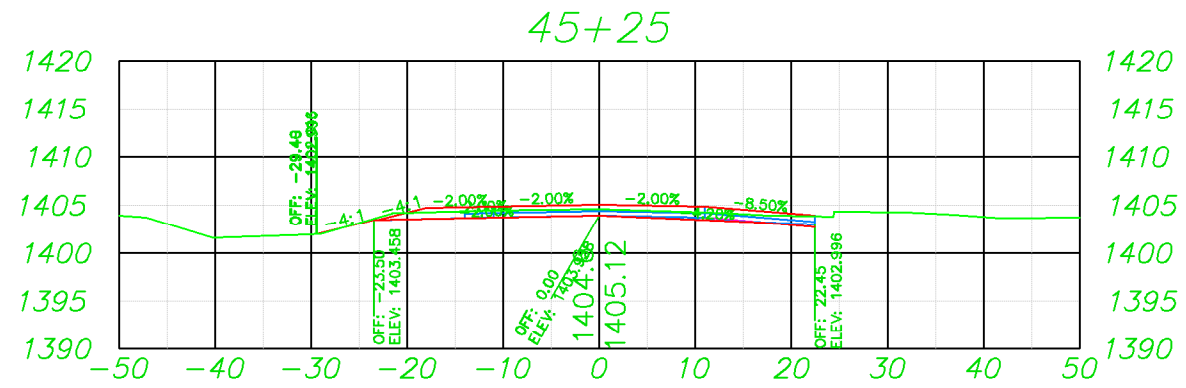

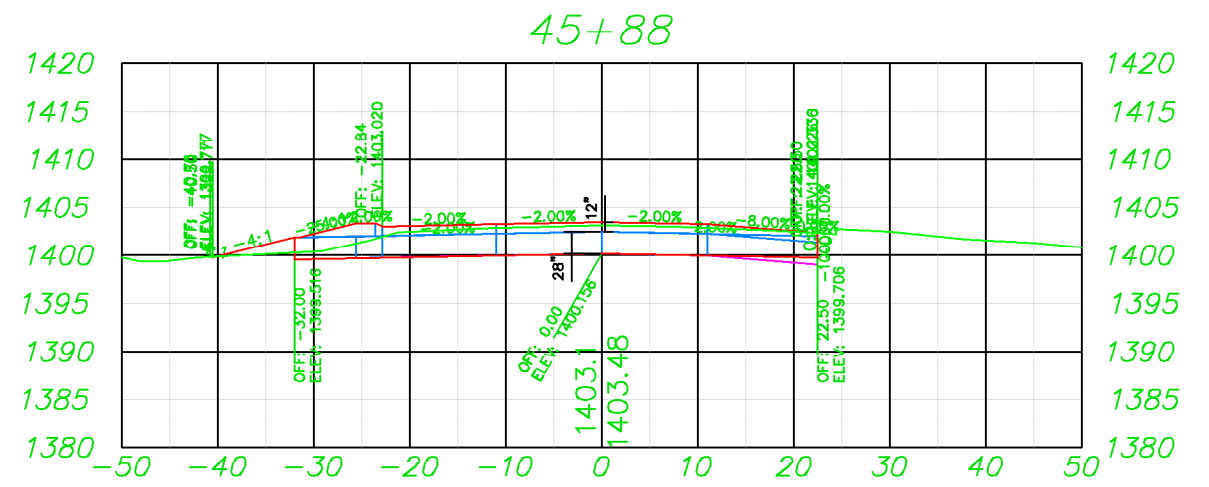
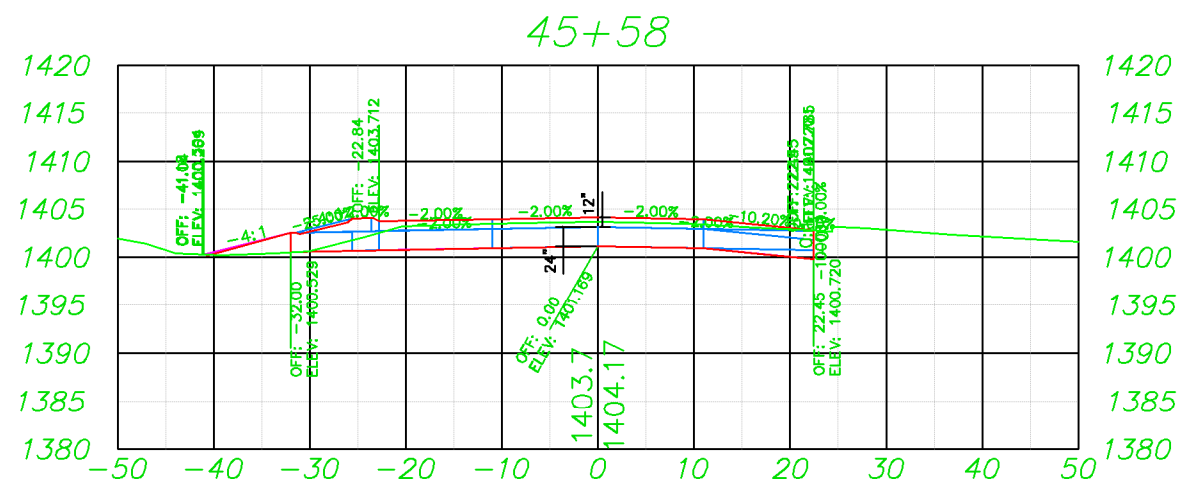
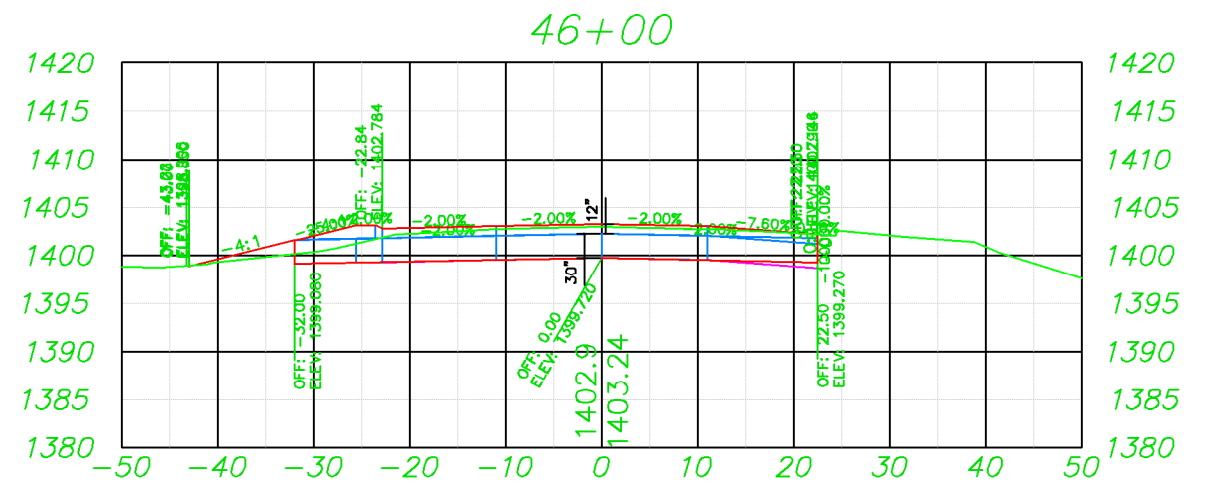
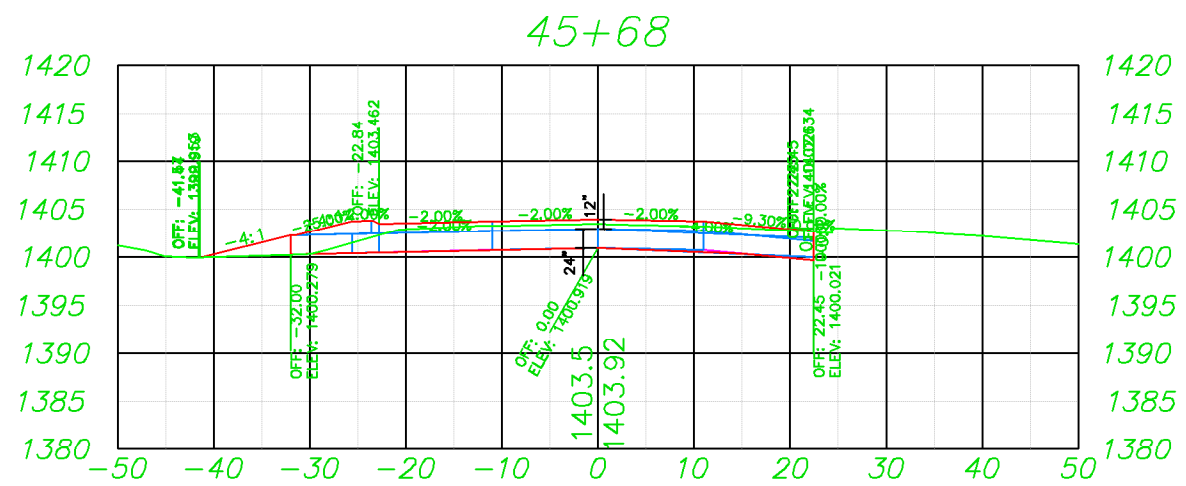
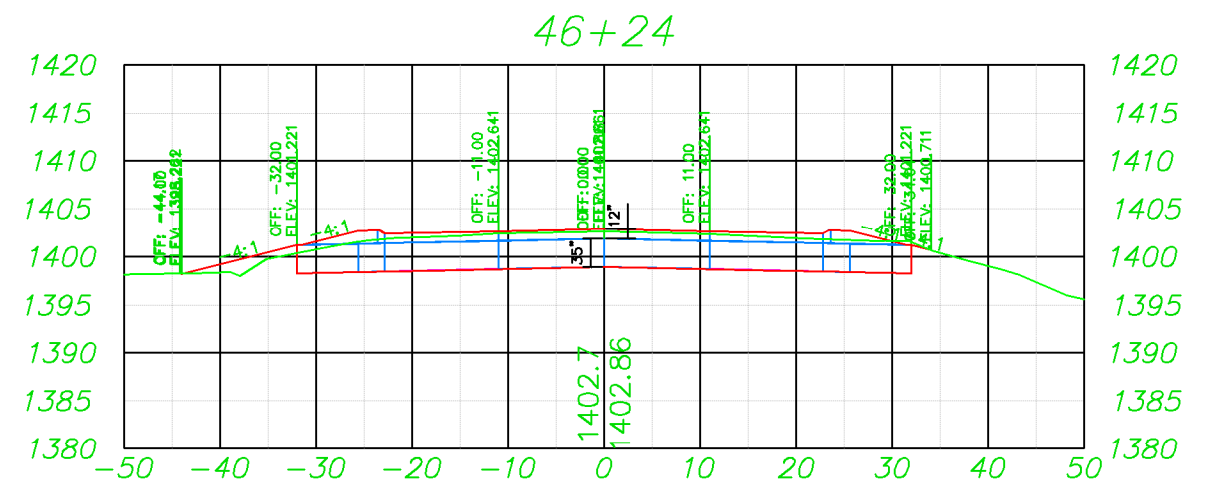
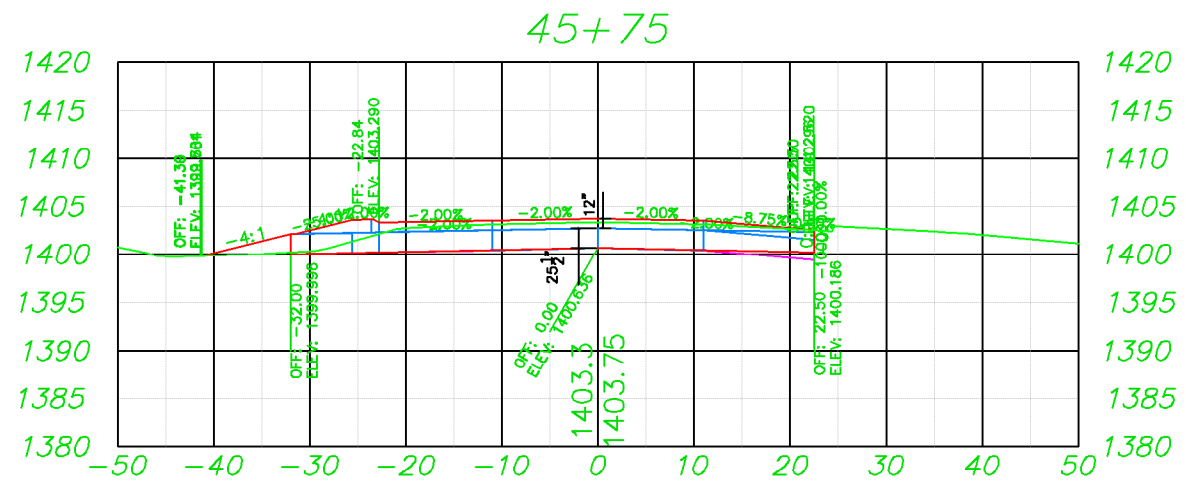

Scale 1" = 20 ft. Horiz. & Vert.

2025-2026 CONSTRUCTION

DICKINSON COUNTY

PROJECT NUMBER L-669-73-30

STATE	FHWA REGION	FISCAL YEAR	SHEET NO.	TOTAL SHEETS
IOWA	7	2026	W.03	.

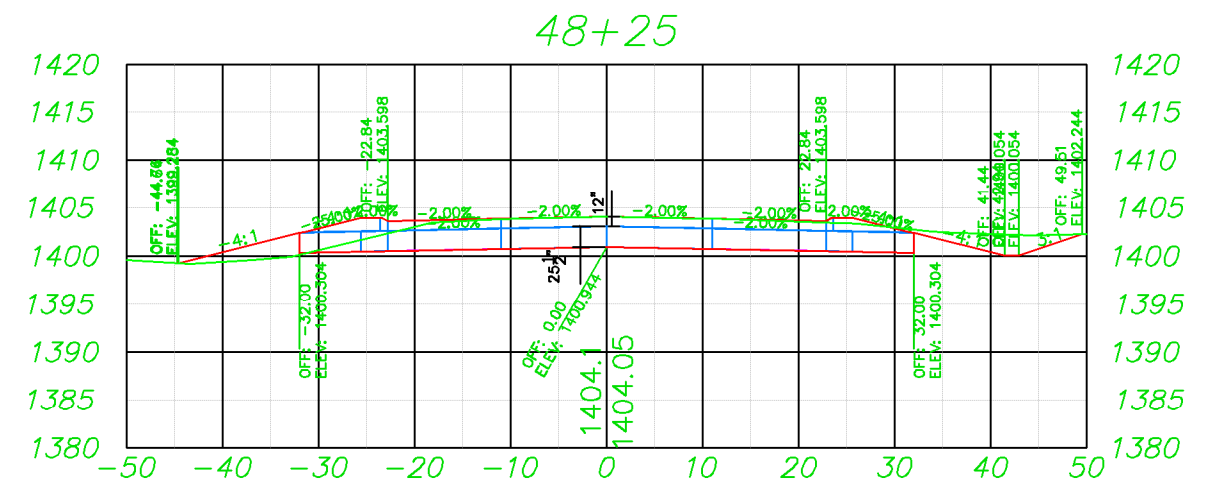
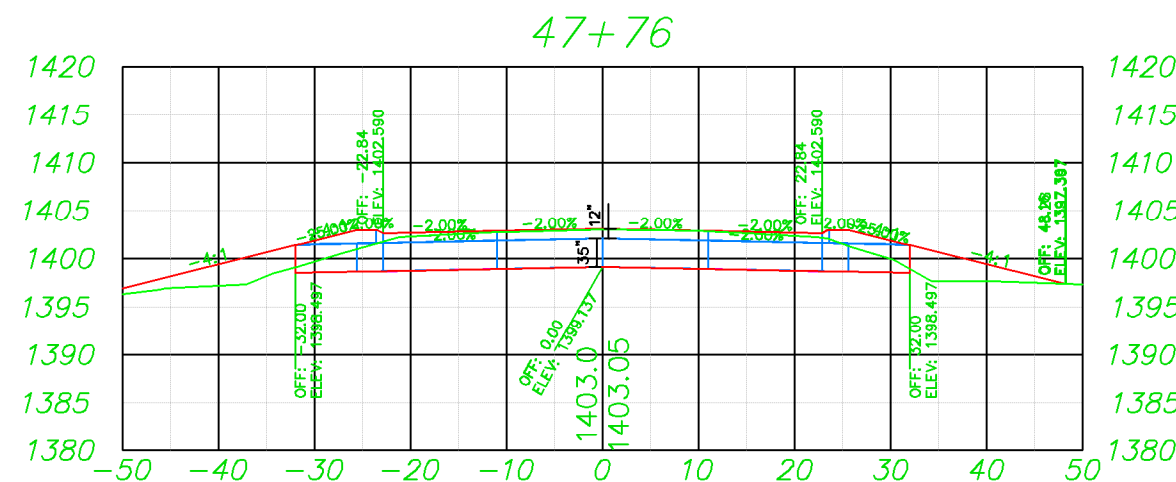
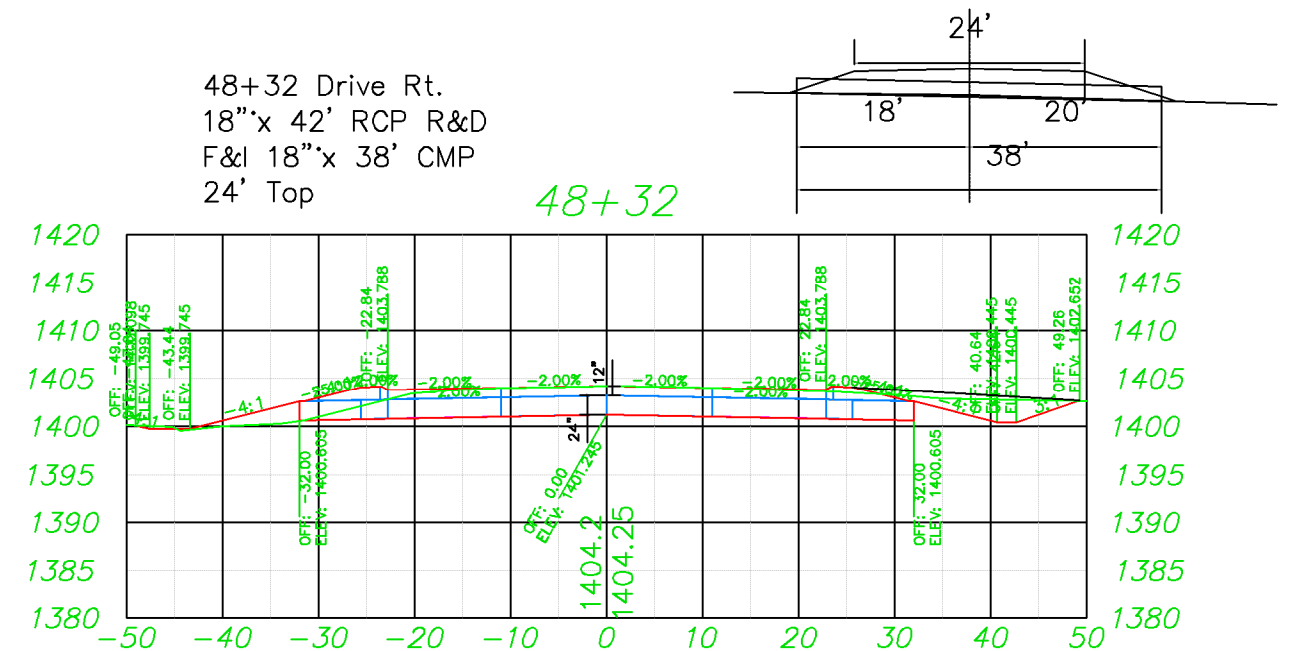
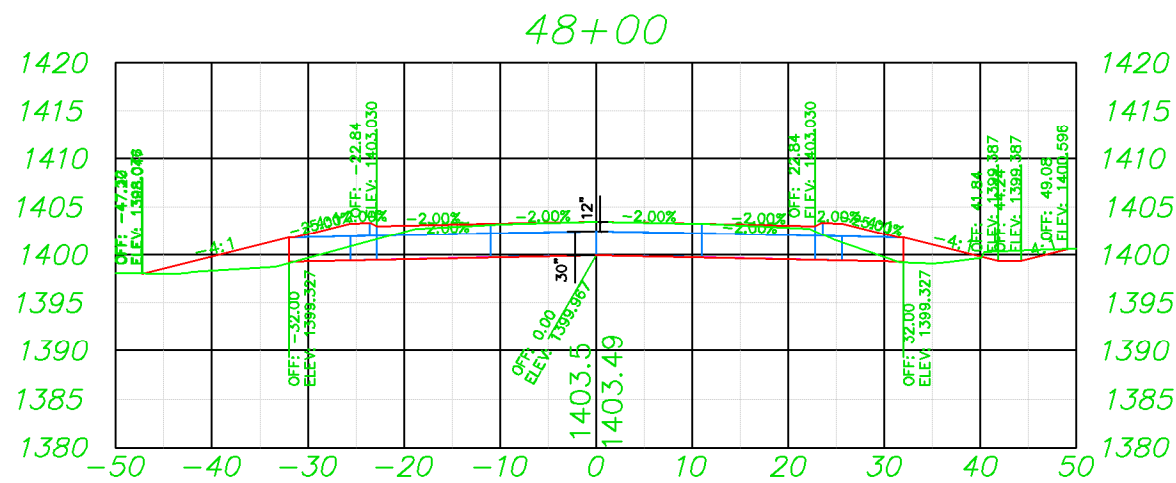
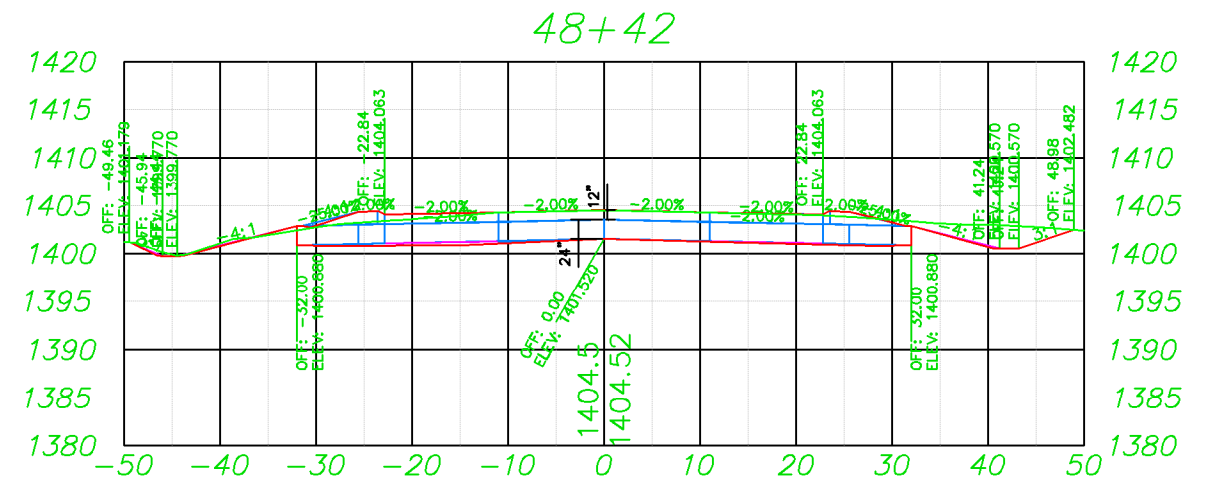
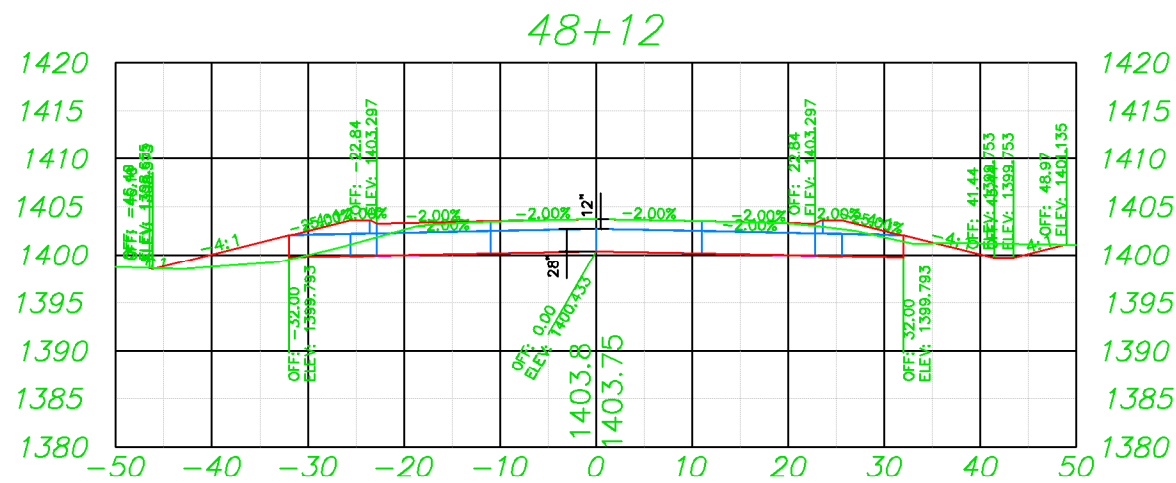

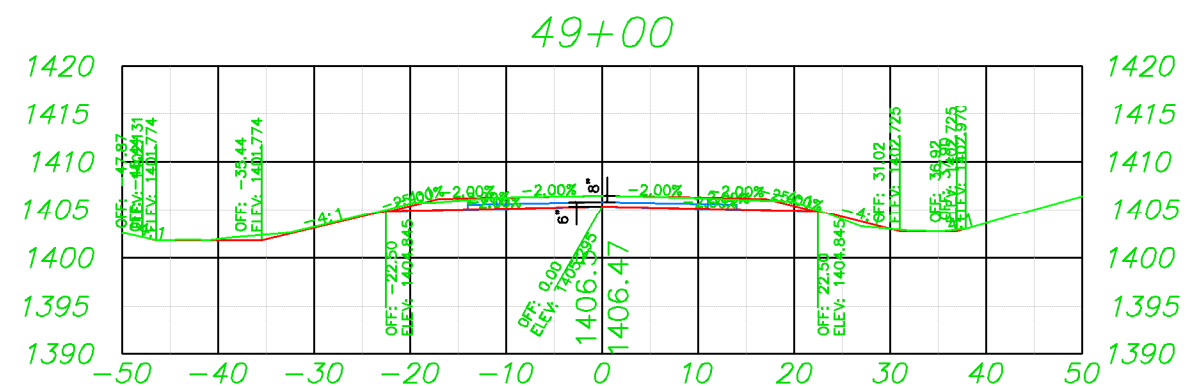
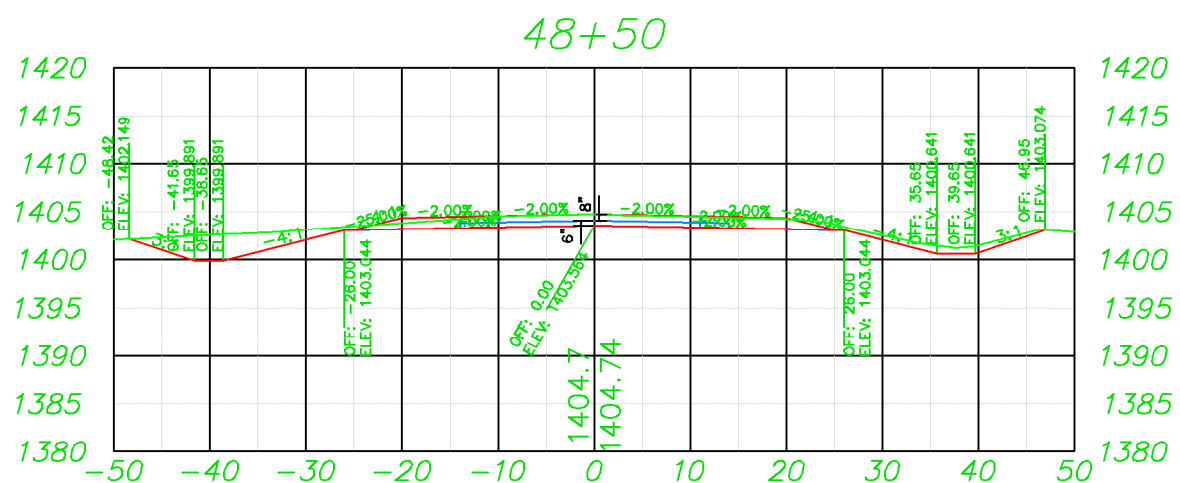
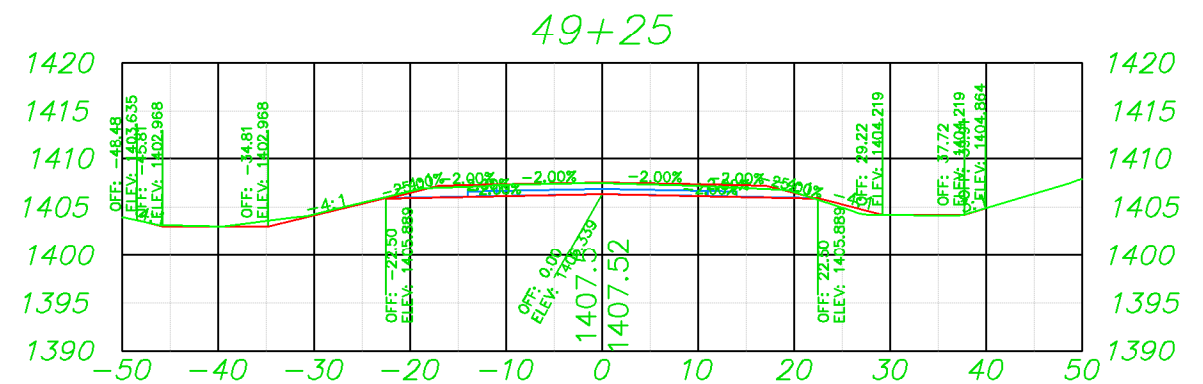
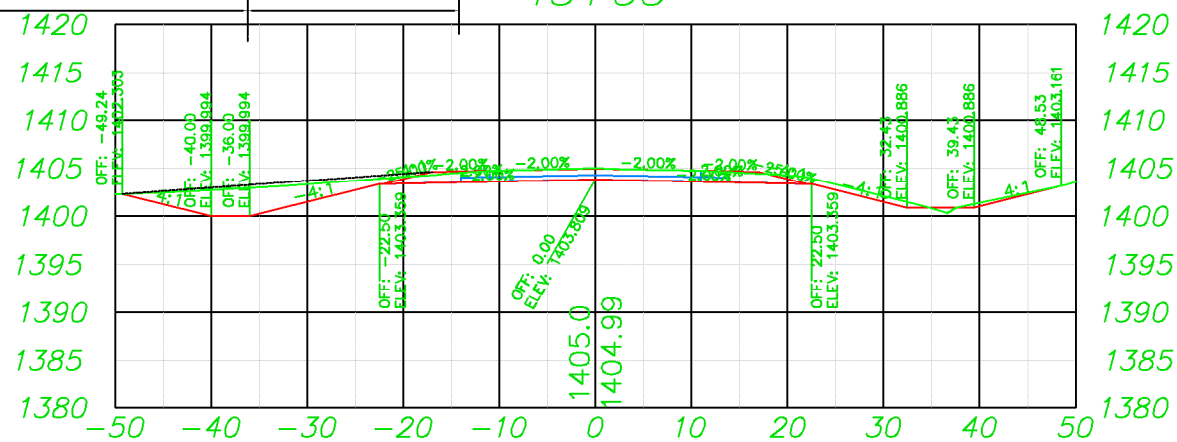
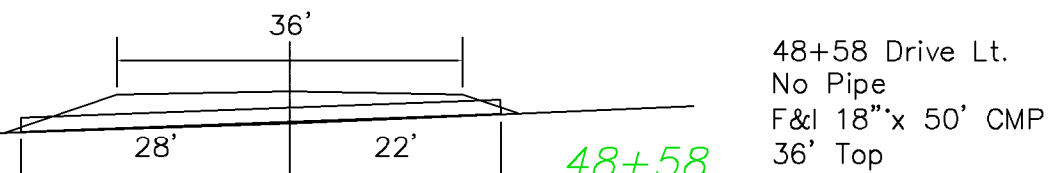
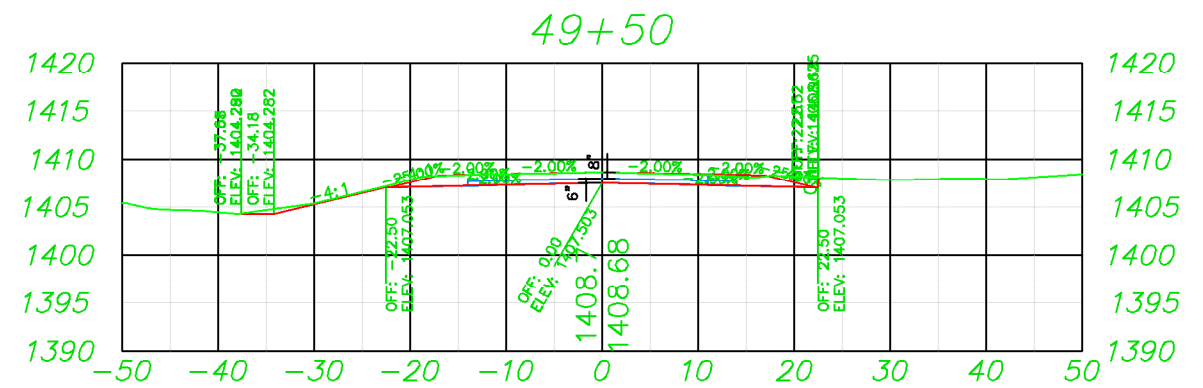
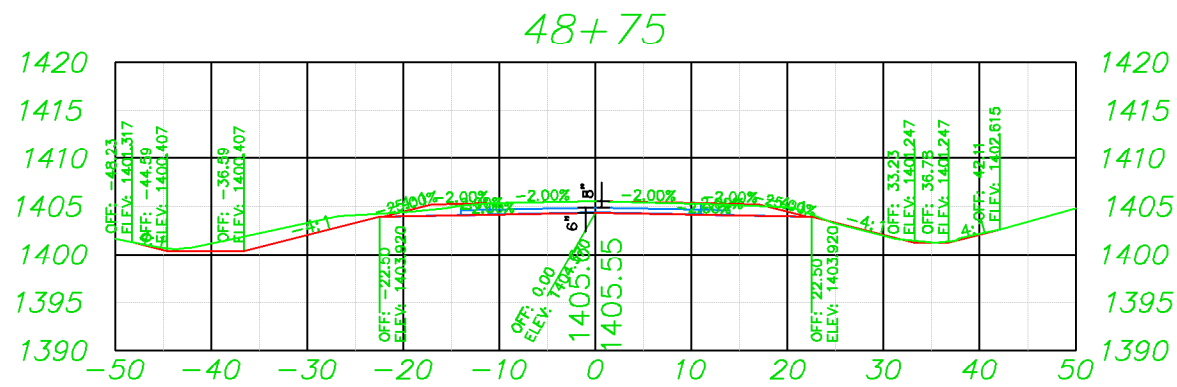

Scale 1" = 20 ft. Horiz. & Vert.

2025-2026 CONSTRUCTION

DICKINSON COUNTY

PROJECT NUMBER

L-669-73-30

STATE
IOWA

FHWA
REGION
7

FISCAL
YEAR
2026

SHEET
NO.
W.05

TOTAL
SHEETS
.